

# Steel Ball Valves

Trunnion Mounted Ball Design, Successfully Fire-tested



# KITZ Ball Valves

## Trunnion Mounted Ball Design

### Contents

---

Design and inspection standards .....	2	Class 300 Carbon / Stainless Steel Ball Valves .....	10
Product Coding .....	2	Class 600 Carbon / Stainless Steel Ball Valves .....	12
Product Range .....	3	Class 900 Carbon / Stainless Steel Ball Valves .....	14
Component Drawing .....	4	Class 1500 Carbon / Stainless Steel Ball Valves .....	16
Design Features .....	5	Exploded Diagram .....	18
Pressure-Temperature Ratings .....	6	Material of Carbon Steel Valve (WCB) .....	19
Flow Characteristics .....	7	Material of Stainless Steel Valve (CF8) .....	20
Class 150 Carbon / Stainless Steel Ball Valves .....	8		

# KITZ Ball Valves Trunnion Mounted Ball Design

## Design and inspection standards

item	Design Standards	
Pressure-temperature ratings	Body	ASME B16.34
	Resilient sealing parts	KITZ Standard
Shell wall thickness	ASME B16.34	
Bore dimensions	API 6D	
Face-to-Face dimensions	ASME B16.10	
End flange dimensions and Flange gasket facing	ASME B16.5*1	
Pressure test	API598 or API6D *2	

Note: \*1 MSS SP-44 for size 22.  
MSS SP-44 and ASME B16. 47 Series A for size 26 & over.  
\*2 Option.

## Product Coding

### Example:

**G- 150 SC T C S BL**  
**G- 150 U T C R S M**

① ② ③ ④ ⑤ ⑥ ⑦ ⑧ ⑨

#### ① Valve operation

None ..... Lever handle  
G ..... Worm gear  
E ..... Electric actuator  
B ..... KITZ Type B actuator  
BS ..... KITZ Type BS actuator  
BSW ..... KITZ Type BSW actuator  
FA ..... KITZ Type FA actuator  
FAS ..... KITZ Type FAS actuator

#### ② End connection

None ..... Raised face flanged ends  
(standard)  
W ..... Butt-welding ends(option)

#### ③ ASME Class

150,300,600,900 or 1500

#### ④ Shell material

SC ..... Carbon or low alloy steel  
U ..... Stainless steel

#### ⑤ Symbol for ball valves

#### ⑥ Symbol for trunnion ball valves

#### ⑦ Bore design

None ..... Full bore  
R ..... Reduced bore

#### ⑧ symbol for super-firesafe design

#### ⑨ Special shell material

An additional symbol is suffixed here,  
if other than WCB or CF8 is employed for  
shell material, such as:

M ..... CF8M  
BL ..... LCB

Other special body material,contact to  
KITZ corporation

Super Duplex Stainless Steel  
Duplex Stainless Steel  
Nickel Based Alloy

Product Range

			Body Material		Carbon Steel										Stainless Steel																											
			Class		150		300		600		900		1500		150		300		600		900		1500																			
KITZ Code			G-150SCTC		G-150SCTCR		G-300SCTC		G-300SCTCR		G-600SCTC		G-600SCTCR		G-900SCTC		G-900SCTCR		G-1500SCTC		G-1500SCTCR		G-150UTC		G-150UTCRCR		G-300UTC		G-300UTCRCR		G-600UTC		G-600UTCRCR		G-900UTC		G-900UTCRCR		G-1500UTC		G-1500UTCRCR	
Bore ※1			F	R	F	R	F	R	F	R	F	R	F	R	F	R	F	R	F	R	F	R	F	R	F	R	F	R	F	R	F	R	F	R	F	R	F	R				
Nominal Size	2	50	●		●		●		●		●		●		●		●		●		●		●		●		●		●		●		●		●		●		●			
	3	80	●	●	●	●	●	●	●	●	●	●	●	●	●	●	●	●	●	●	●	●	●	●	●	●	●	●	●	●	●	●	●	●	●	●	●	●	●	●		
	4	100	●	●	●	●	●	●	●	●	●	□	●	●	●	●	●	●	●	●	●	●	●	●	●	●	●	●	●	●	●	●	●	□	●	●	●	●	●	●		
	6	150	●	●	●	●	●	●	●	□	●	□	□	□	●	●	●	●	●	●	●	●	●	●	●	□	●	●	□	□	□	□	□	□	□	□	□	□	□	□		
	8	200	●	●	●	●	□	●	□	□	□	□	□	□	●	●	●	●	●	●	□	□	□	□	□	□	□	□	□	□	□	□	□	□	□	□	□	□	□	□		
	10	250	□	●	□	●	□	□	□	□	□	□	□	□	□	●	□	●	□	□	□	□	□	□	□	□	□	□	□	□	□	□	□	□	□	□	□	□	□	□		
	12	300	□	□	□	□	□	□	□	□	□	□	□	□	□	□	□	□	□	□	□	□	□	□	□	□	□	□	□	□	□	□	□	□	□	□	□	□	□	□		
	14	350	□	□	□	□	□	□	□	□	□	□	□	□	□	□	□	□	□	□	□	□	□	□	□	□	□	□	□	□	□	□	□	□	□	□	□	□	□	□		
	16	400	□	□	□	□	□	□	□	□	□	□	□	□	□	□	□	□	□	□	□	□	□	□	□	□	□	□	□	□	□	□	□	□	□	□	□	□	□	□		
	18	450	□	□	□	□	□	□	□	□	□	□	□	□	□	□	□	□	□	□	□	□	□	□	□	□	□	□	□	□	□	□	□	□	□	□	□	□	□	□		
	20	500	□	□	□	□	□	□	□	□	□	□	□	□	□	□	□	□	□	□	□	□	□	□	□	□	□	□	□	□	□	□	□	□	□	□	□	□	□	□		
	22	550	□	□	□	□																																				
	24	600	□	□	□	□	□	□	□	□					□	□	□	□	□	□	□	□	□	□	□	□	□	□	□	□	□	□										
	26	650	□	□	□	□	□	□							□	□	□	□	□	□	□	□	□	□	□	□																
	28	700	□	□	□	□	□	□							□	□	□	□	□	□	□	□	□	□	□	□																
	30	750	□	□	□	□	□	□							□	□	□	□	□	□	□	□	□	□	□	□																
	32	800	□	□	□	□									□	□	□	□	□	□																						
34	850	□	□	□	□									□	□	□	□	□	□																							
36	900	□	□	□	□									□	□	□	□	□	□																							

• Lever operation is standard for the size marked ●, without the prefix "G" on each KITZ Fig.

• Gear operation is standard for the size marked □.

Electric or pneumatic actuators are optionally available. Contact your KITZ agent or distributor for appropriate choice and sizing of valve actuators.

※ 1 F : Full Bore R : Reduced Bore

Component Drawing

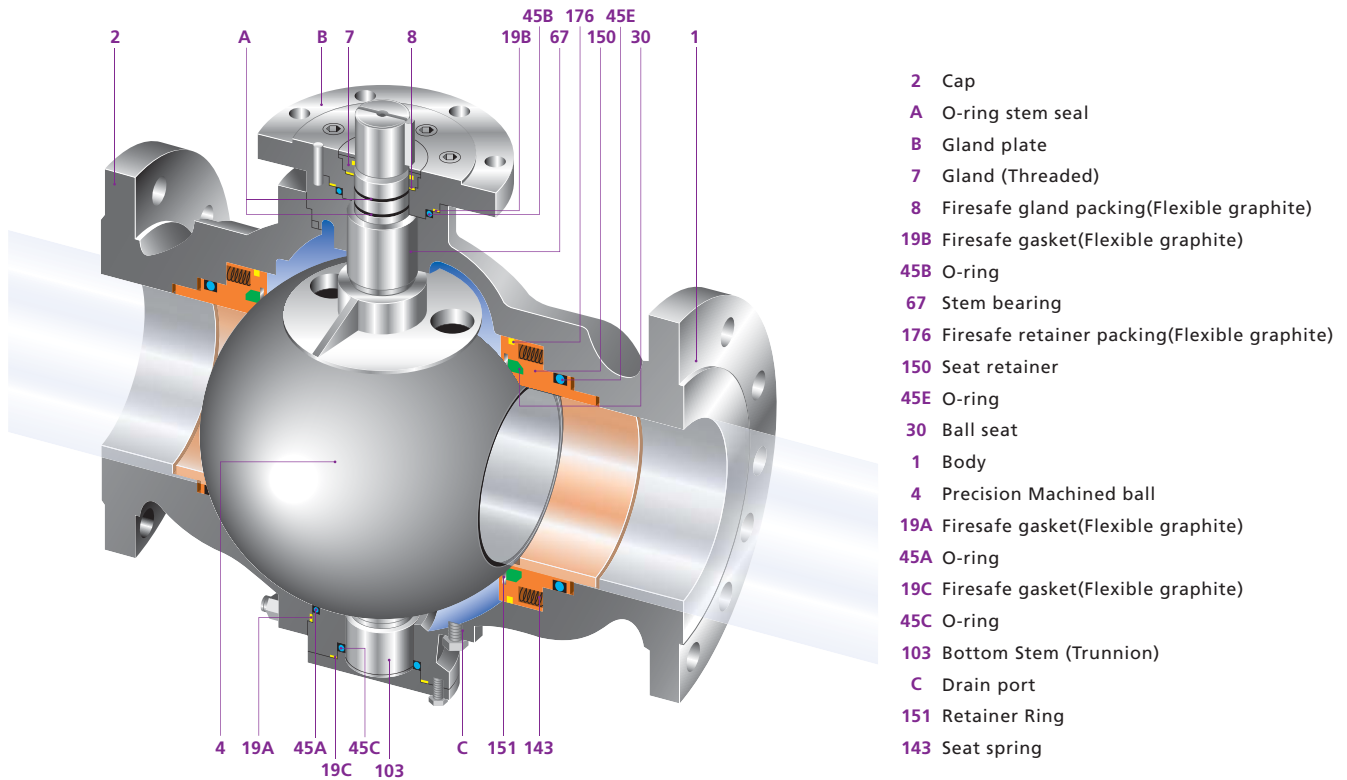

- 2 Cap
- A O-ring stem seal
- B Gland plate
- 7 Gland (Threaded)
- 8 Firesafe gland packing(Flexible graphite)
- 19B Firesafe gasket(Flexible graphite)
- 45B O-ring
- 67 Stem bearing
- 176 Firesafe retainer packing(Flexible graphite)
- 150 Seat retainer
- 45E O-ring
- 30 Ball seat
- 1 Body
- 4 Precision Machined ball
- 19A Firesafe gasket(Flexible graphite)
- 45A O-ring
- 19C Firesafe gasket(Flexible graphite)
- 45C O-ring
- 103 Bottom Stem (Trunnion)
- C Drain port
- 151 Retainer Ring
- 143 Seat spring

Where requirement of the firesafe provision is less stringent, valves may be optionally provided with sealing materials other than flexible graphite, for economic advantage. Contact Kitz Corporation for more details.

\*The illustration shown in this catalog represents the typical structure of class 600 valves.

The structure may differ depending on size and class. Please consult Kitz for more details on the specifications and structure of the valve.

Design Features

1. Super-firesafe Design.

(1) Internal leakage prevention:

When resilient sealing materials are decomposed or deteriorated by a plant fire, the edge of the metal seat retainer preloaded by the seat spring comes into contact with the ball to shut off the line fluid to minimize internal leakage through the valve bore. The seat retainer also compresses Kitz originally designed flexible graphite retainer packings to prevent fluid leakage from between the valve body and the seat retainer (PATENTED).

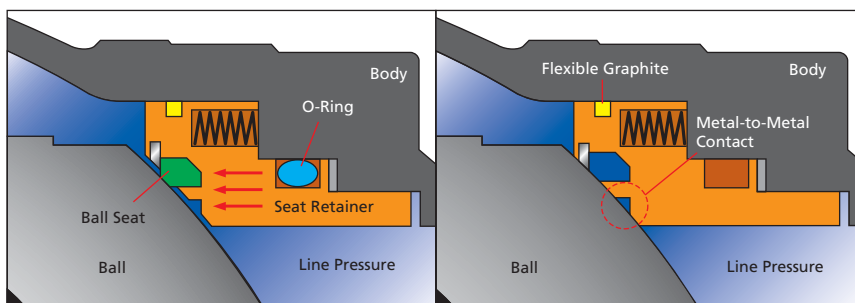

(2) External leakage prevention

Leakage from the valve stem area is prevented by double sealing with O-ring and flexible graphite gland packings. Leakage through the valve body joint is also protected by double sealing with O-rings and flexible graphite gaskets. After a fire has deteriorated O-rings, flexible graphite packings and gaskets are the measure that prevents external fluid leakage.

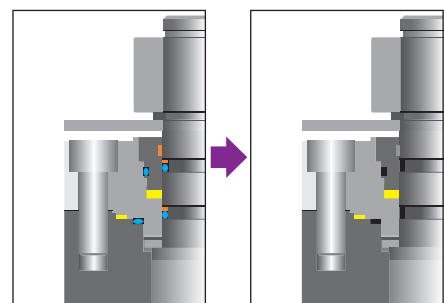

## Design Features

### 2.Tight Shut-off Sealing Mechanism

A floating seat design is employed so that each of the upstream and downstream seats is adequately maintained in contact with the ball by means of a seat spring. Line pressure helps this contact method. It features excellent sealing performance independently on both side seats at the same time.

### 3.Block and Bleed Function.

Ball seats shut off the line fluid independently on the upstream and downstream side of the ball. The valve bore and the body cavity are isolated from each other when the valve is fully opened or closed so that the residue within the body cavity may be disposed through the drain port or an optional vent valve mounted on the bottom of the valve body. The design prevents fluid contamination within the valve interior and easily detects seat leakage from both flow directions, without dismantling the valve from the pipeline.

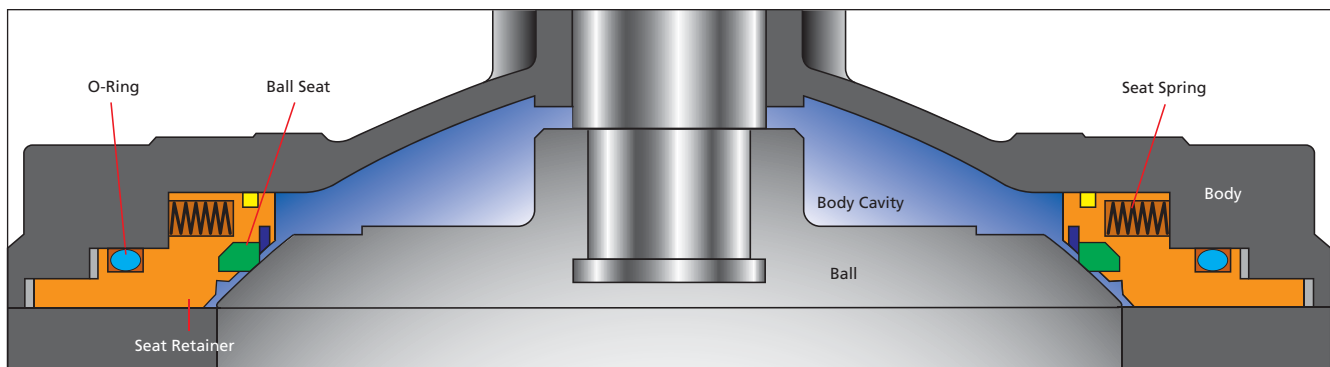

### 4.Cavity Pressure Relief.

In case of an unusually high increase of servicing or ambient temperature, liquefied gas or highly volatile liquid trapped within the body cavity may evaporate, and cause an excessive rise in the cavity pressure. For safety consideration, a provision is made so that when the cavity pressure exceeds the line pressure, the ball seat will move slightly away from the ball surface to relieve the excessive cavity pressure into the valve bore.

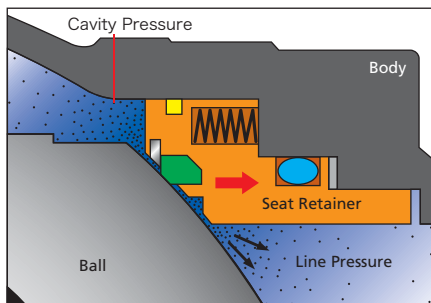

### 5.Low Emission Design

The emission suppressing design of Kitz trunnion mounted ball valves is guaranteed by the production test carried out at factories prior to shipment. In the United States, the Federal Clean Air Act was dramatically amended in 1990, to realize the new environmental protection policy of a 95% reduction in fugitive emission or leak levels of toxic gases and chemicals from plant equipment. Promulgated in April, 1994, the new law requires all plants handling

the toxic gas specified by the Environmental Protection Agency, to periodically monitor their plant equipment for detection of leaks exceeding 500 ppm, and repair or replace all defective parts immediately. California has exceeded the Federal law with a state regulation requiring 100 ppm maximum leak level for an astonishing 99% reduction of such an environmental pollution for the Northern California Region after 1997.

### 6.Options

#### (1) Emergency Seal Restoration.

For accidental leakage from the seat or stem sealing area, a sealant supply mechanism may be provided as an option. Should the sealing material be damaged or decomposed by fire or other accidental causes, leakage can be temporarily prevented by injection of the sealant into this mechanism.

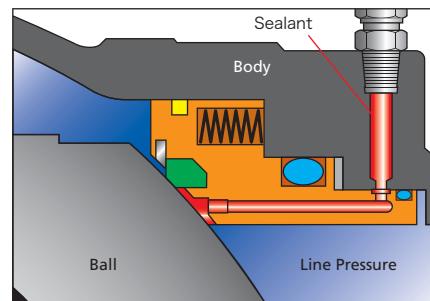

#### (2) Low Temperature, cryogenic Temperature.

#### (3) Stem Extension.

Please contact your Kitz agent or distributor.

**Pressure-Temperature Ratings**

The pressure-temperature rating of soft-seated ball valves are determined, not only by the valve shell materials, but also by the sealing materials used for ball seat, gland packings, O-rings, and flange gaskets. Sealing materials may be high molecule, or rubber, but the choice is limited by characteristics of the service fluid, working pressures, fluid velocity, and operational frequency of valves.

As it is very difficult to predetermine the exact pressure-temperature ratings for all kinds of fluid under all imaginable conditions, we have prepared general rating charts for non-shock fluid service below, based on our past experiences both in the field and in our laboratory. Frequent need of maintenance is another factor to be kept in mind, if very high temperature operation is planned or expected.

**Class 150/300/600**

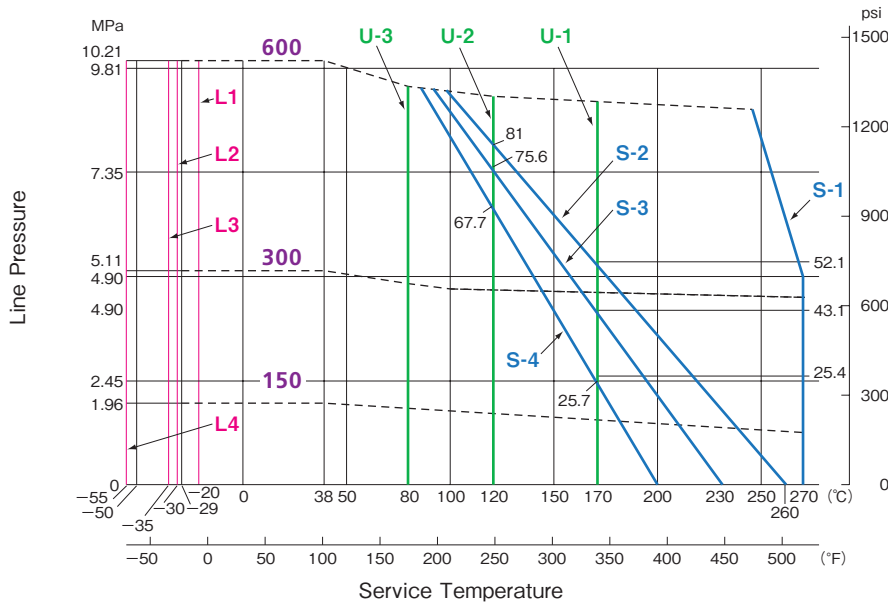

**Ball Seat Rating**

- S - 1 : Modified PEEK\*
- S - 2 : Carbon-filled PTFE
- S - 3 : (1)KITZ HYPATITE®  
(2)Glass-filled PTFE  
(3)Glass-filled PTFE with MoS2  
(Standard for Class 150,300,&600)
- S - 4 : Virgin PTFE
- S - 5 : Reinforced Nylon  
(Standard for Class 900&1500)

Modified PEEK\* : Lower temperature limit is -30°C(-22°F).  
Special care should be taken to select Modified PEEK based on chemical compatibility with the service.  
Contact KITZ Corporation for application engineering details.  
Modified PEEK is available for 12 and smaller valves.

\* Poly Ether Ether Ketone.

**Class 900/1500**

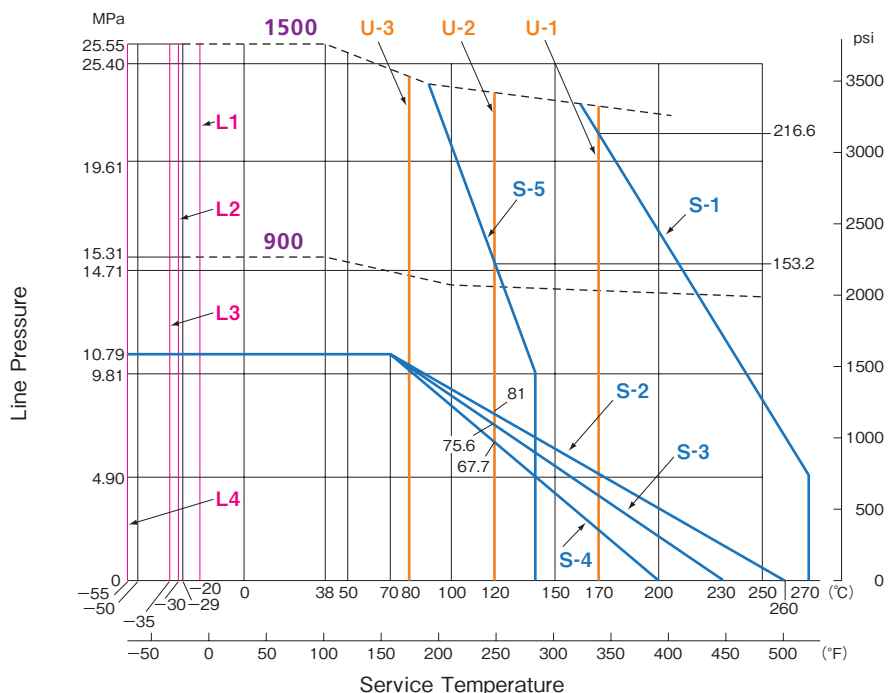

**O-ring Upper Limits**

- U - 1 : (1)FKM(Standard for stainless steel valves)  
(2)Low-temperature FKM
- U - 2 : (1)EPDM
- U - 3 : (1)NBR(Standard for carbon steel valves)  
(2)Low-temperature NBR

**O-ring Lower Limits**

- L - 1 : (1)FKM(Standard for stainless steel valves)
- L - 2 : (1)EPDM  
(2)NBR(Standard for carbon steel valves)
- L - 3 : Low-temperature FKM
- L - 4 : Low-temperature NBR

**Flow Characteristics**

One of the best advantages of ball valves is that every flow per any given bore size is larger than other types of valves. Fluid is much less disturbed by eddy currents or pulsation. To obtain the figure of flow per valve opening, simply multiply the flow rate (%) given here by the corresponding value given in the table of Pressure Loss vs. Flow Rate.

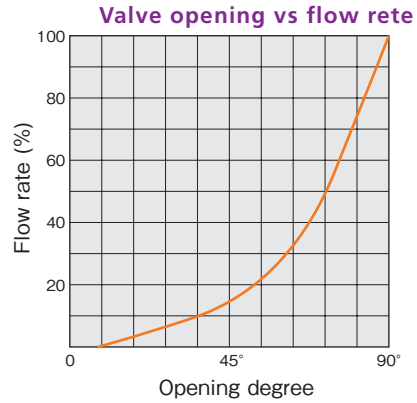

**Class 150/300/600**

**150SCTC, 150UTC**

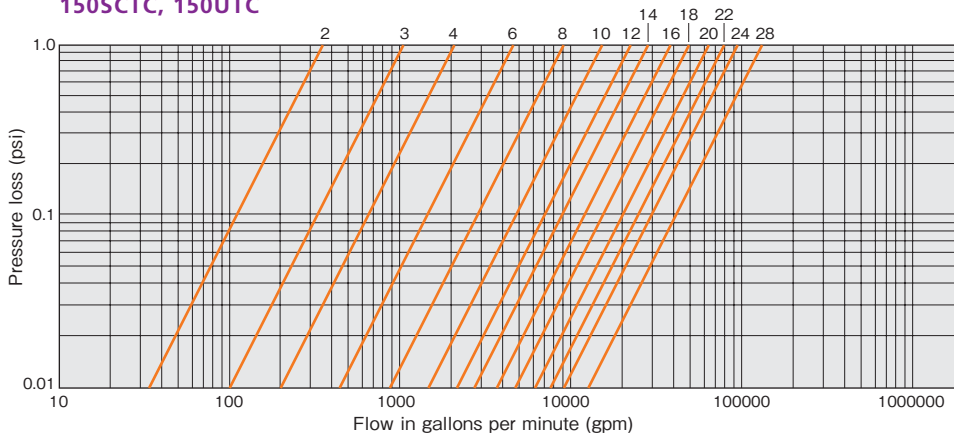

**150SCTCR, 150UTC**

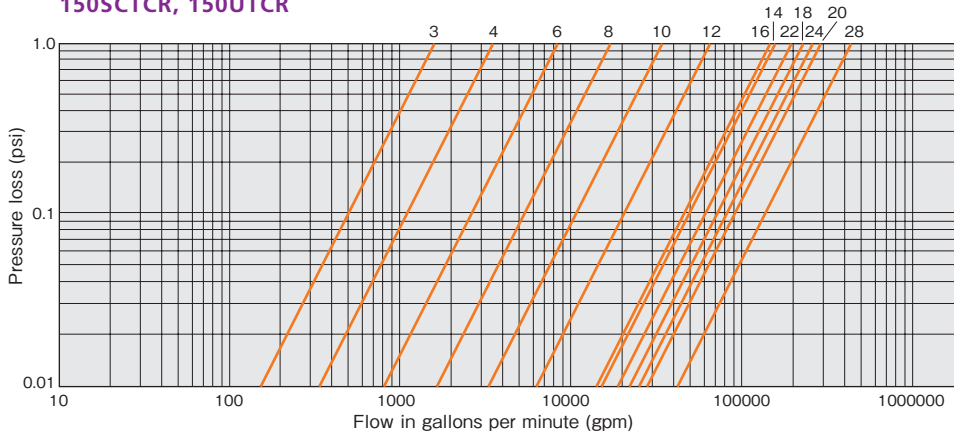

**Schedule 40 steel pipe (10m)**

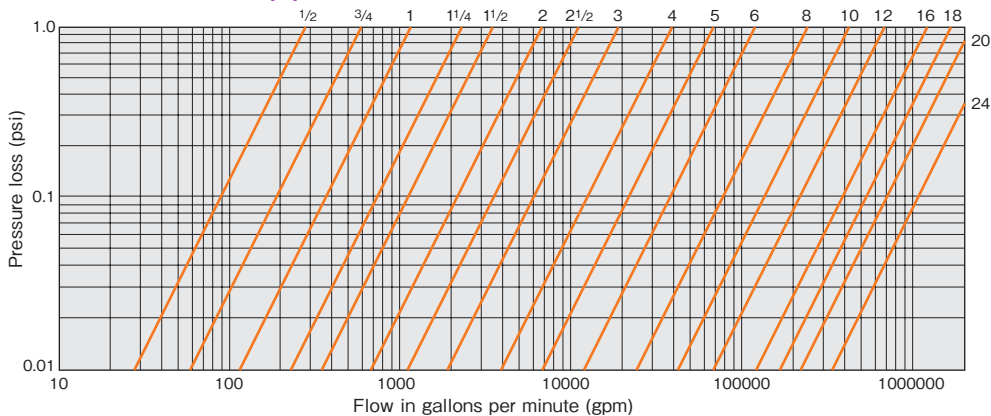



**Class 150**

**Carbon/Stainless Steel Ball Valves**

Split body, side entry design

**Fig.G-150SCTCS**

Full Bore

**Fig.G-150UTCS**

Full Bore

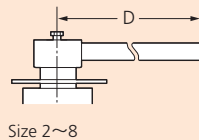
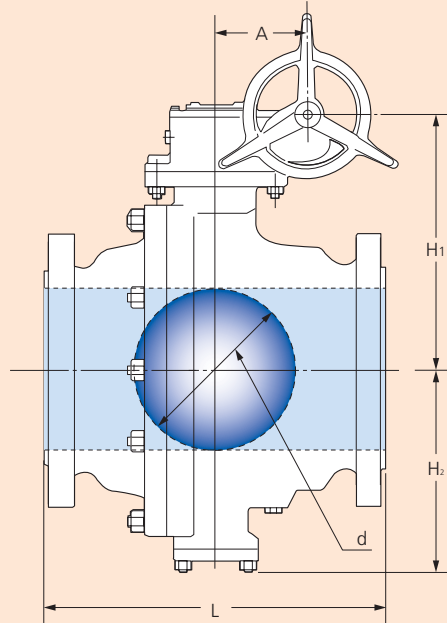

Size 2~8

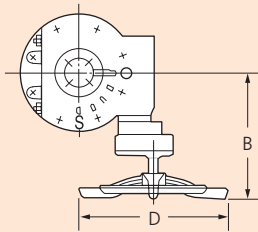

Size 10~32

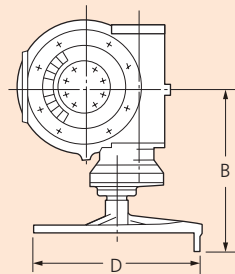

Size 34 & over

**Fig.(G-)150SCTCS / (G-)150UTCS**

	Nominal Size	2	3	4	6	8	10	12	14	16	18	20	22	24	26	28	30	32	34	36	
		mm	mm	mm	mm	mm	mm	mm	mm	mm	mm	mm	mm	mm	mm	mm	mm	mm	mm	mm	mm
Full Bore	Bore d	2	3	4	6	8	10	12	13.25	15.25	17.25	19.25	21.25	23.25	25	27	29	30.75	32.75	34.5	
		51	76	102	152	203	254	305	337	387	438	489	540	591	635	686	737	781	832	876	
	L	7	8	9	15.5	18	21	24	27	30	34	36	40	42	45	49	51	54	58	60	
		178	203	229	394	457	533	610	686	762	864	914	1016	1067	1143	1245	1295	1372	1473	1524	
H1	inch	6.50	7.60	9.09	12.95	15.47	15.47	17.36	18.94	23.54	25.31	27.87	31.42	33.98	33.86	35.42	37.01	38.98	39.65	41.14	
	mm	165	193	231	329	393	393	441	481	598	643	708	798	863	860	895	940	990	1007	1045	
H2	inch	3.98	5.04	6.02	8.62	10.75	13.35	15.16	16.69	18.54	20.24	22.80	24.72	27.17	26.97	28.35	30.51	32.48	34.21	35.71	
	mm	101	128	153	219	273	339	385	424	471	514	579	628	690	685	720	775	825	869	907	
Operation		Lever						Gear													

**Class 150**

**Carbon/Stainless Steel Ball Valves**

Split body, side entry design

**Fig.G-150SCTCRS**

Reduced Bore

**Fig.G-150UTCRS**

Reduced Bore

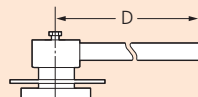
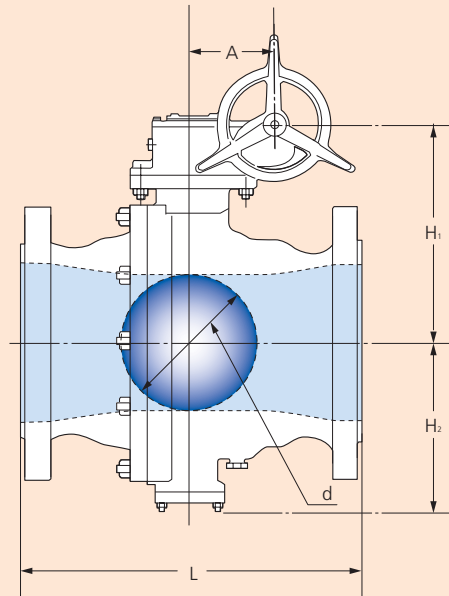

Size 3×2×3 to 10×8×10

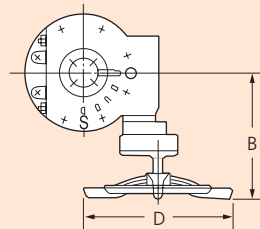

Size 12×10×12 & over

**Fig.(G-)150SCTRS / (G-)150UTCRS**

	Nominal Size	inch	2	3	4	6	8	10	12	14	16	18	20	22	24	26	28	30	32	34	36	
		mm	50	80	100	150	200	250	300	350	400	450	500	550	600	650	700	750	800	850	900	
Reduced Bore	Bore d	inch		2	3	4	6	8	10	12	13.25	15.25	17.25	17.25	19.25	21.25	23.25	23.25	25	27	29	
		mm		51	76	102	152	203	254	305	337	387	438	438	489	540	591	591	635	686	737	
	L	inch		8	9	15.5	18	21	24	27	30	34	36	40	42	45	49	51	54	58	60	
		mm		203	229	394	457	533	610	686	762	864	914	1016	1067	1143	1245	1295	1372	1473	1524	
	H1	inch		6.50	7.60	9.09	12.95	15.47	15.47	17.36	18.94	23.54	25.31	25.31	27.87	31.42	33.98	33.98	33.86	35.42	37.01	
	mm		165	193	231	329	393	393	441	481	598	643	643	708	798	863	863	860	895	940		
	H2	inch		3.98	5.04	6.02	8.62	10.75	13.35	15.16	16.69	18.54	20.24	20.24	22.80	24.72	27.17	26.97	28.35	30.51		
	mm			101	128	153	219	273	339	385	424	471	514	514	579	628	690	685	720	775		
Operation			Lever						Gear													

**Class 300**

**Carbon/Stainless Steel Ball Valves**

Split body, side entry design

**Fig.G-300SCTCS**

Full Bore

**Fig.G-300UTCS**

Full Bore

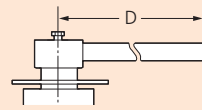
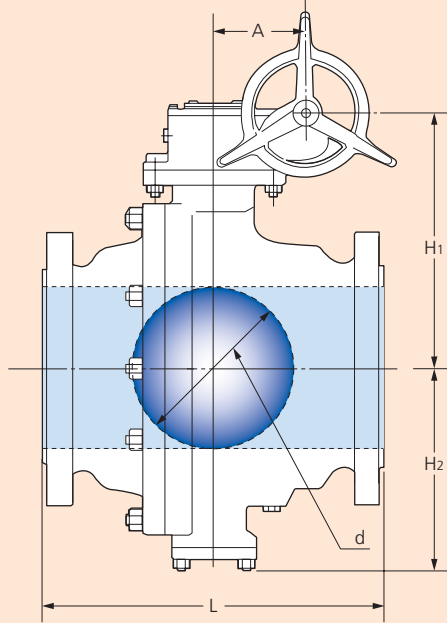

Size 2~8

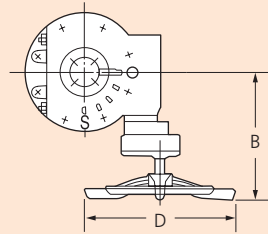

Size 10~28

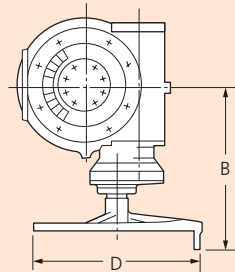

Size 30 & over

**Fig.(G-)300SCTCS / (G-)300UTCS**

	Nominal Size	2	3	4	6	8	10	12	14	16	18	20	22	24	26	28	30	32	34	36	
		inch	mm	inch	mm	inch	mm	inch	mm	inch	mm	inch	mm	inch	mm	inch	mm	inch	mm	inch	mm
Full Bore	Bore d	inch	2	3	4	6	8	10	12	13.25	15.25	17.25	19.25	21.25	23.25	25	27	29	30.75	32.75	34.5
		mm	51	76	102	152	203	254	305	337	387	438	489	540	591	635	686	737	781	832	876
	L	inch	8.5	11.125	12	15.875	19.75	22.375	25.5	30	33	36	39	43	45	49	53	55	60	64	68
		mm	216	283	305	403	502	568	648	762	838	914	991	1092	1143	1245	1346	1397	1524	1626	1727
H1	inch	6.50	7.60	9.09	12.95	15.47	17.36	18.94	23.54	25.31	27.87	31.42	33.98	35.04	37.20	37.80	39.76	42.52	44.02		
	mm	165	193	231	329	393	441	481	598	643	708	798	863	890	945	960	1010	1080	1118		
H2	inch	3.98	5.04	6.02	8.62	10.75	13.35	15.16	16.69	18.54	20.24	22.80	24.72	27.17	28.15	30.31	32.09	34.06	35.79	37.28	
	mm	101	128	153	219	273	339	385	424	471	514	579	628	690	715	770	815	865	909	947	
Operation		Lever						Gear													

**Class 300**

**Carbon/Stainless Steel Ball Valves**

Split body, side entry design

**Fig.G-300SCTCRS**

Reduced Bore

**Fig.G-300UTCRS**

Reduced Bore

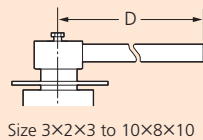
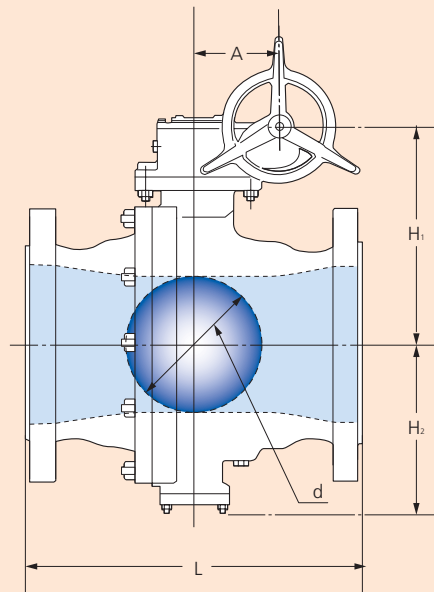

Size 3X2X3 to 10X8X10

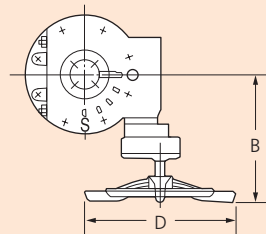

Size 12X10X12~34X28X34

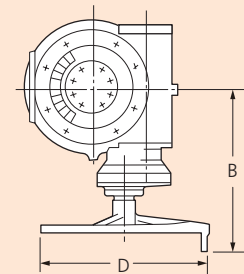

Size 36X30X36 only

**Fig.(G-)300SCTCRS / (G-)300UTCRS**

	Nominal Size	2	3	4	6	8	10	12	14	16	18	20	22	24	26	28	30	32	34	36	
		inch	3	4	6	8	10	12	14	16	18	20	22	24	26	28	30	32	34	36	
Reduced Bore	Bore d	2	3	4	6	8	10	12	14	16	18	20	22	24	26	28	30	32	34	36	
	L	11.125	12	15.875	19.75	22.375	25.5	30	33	36	39	43	45	49	53	55	60	64	68		
	H1	6.50	7.60	9.09	12.95	15.47	17.36	18.94	23.54	25.31	25.31	27.87	31.42	33.98	33.98	35.04	37.20	37.80			
	H2	3.98	5.04	6.02	8.62	10.75	13.35	15.16	16.69	18.54	20.24	20.24	22.80	24.72	27.17	27.17	28.15	30.31	32.09		
	Operation		Lever							Gear											

**Class 600**

**Carbon/Stainless Steel Ball Valves**

Split body, side entry design

**Fig.G-600SCTCS**

Full Bore

**Fig.G-600UTCS**

Full Bore

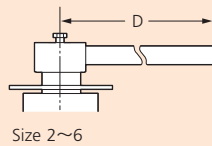
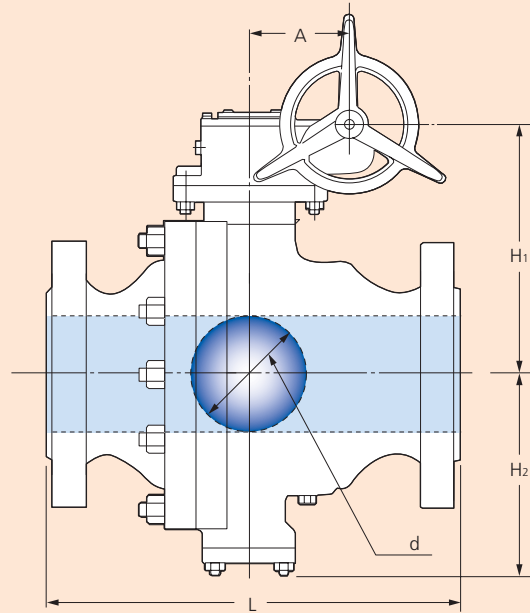

Size 2~6

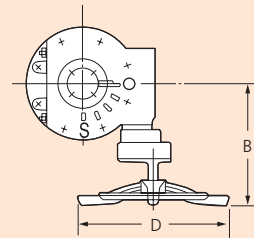

Size 8~24

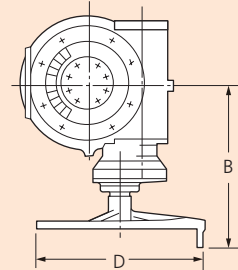

Size 26 & over

**Fig.(G-)600SCTCS / (G-)600UTCS**

	Nominal Size	2	3	4	6	8	10	12	14	16	18	20	22	24	26	28	30	32	34	36	
		mm	mm	mm	mm	mm	mm	mm	mm	mm	mm	mm	mm	mm	mm	mm	mm	mm	mm	mm	mm
Full Bore	Bore d	2	3	4	6	8	10	12	13.25	15.25	17.25	19.25		23.25	25	27	29				
		51	76	102	152	203	254	305	337	387	438	489		591	635	686	737				
	L	11.5	14	17	22	26	31	33	35	39	43	47		55	57	61	65				
		292	356	432	559	660	787	838	889	991	1092	1194		1397	1448	1549	1651				
H1	inch	6.93	9.72	10.87	14.29	16.77	21.57	23.54	25.51	29.13	31.89		36.22	37.20	40.87	42.83					
	mm	176	247	276	363	426	548	598	648	740	810		920	945	1038	1088					
H2	inch	4.69	5.79	6.77	9.84	12.52	14.65	17.09	19.06	21.02	23.23	25.91		30.16	32.48	35.04	36.93				
	mm	119	147	172	250	318	372	434	484	534	590	658		766	825	890	938				
Operation		Lever					Gear														

**Class 600**

**Carbon/Stainless Steel Ball Valves**

Split body, side entry design

**Fig.G-600SCTCRS**

Reduced Bore

**Fig.G-600UTCRS**

Reduced Bore

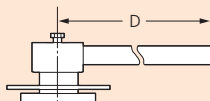
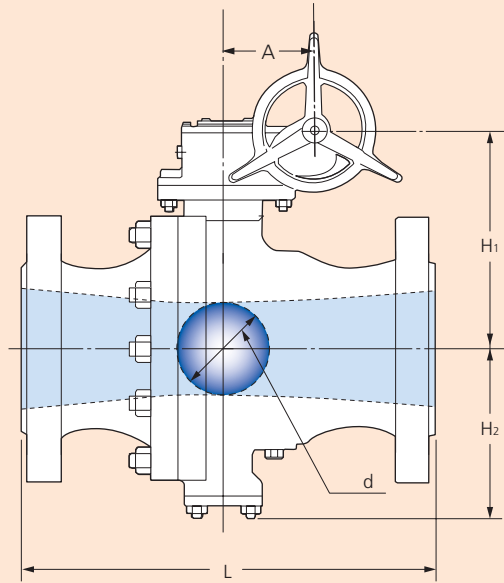

Size 3×2×3 to 8×6×8

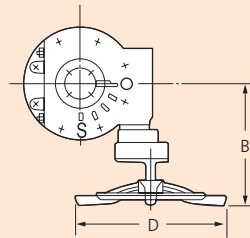

Size 10×8×10 & over

**Fig.(G-)600SCTCRS / (G-)600UTCRS**

	Nominal Size	2	3	4	6	8	10	12	14	16	18	20	22	24	26	28	30	32	34	36	
		inch mm	50	80	100	150	200	250	300	350	400	450	500	550	600	650	700	750	800	850	900
Reduced Bore	Bore d	inch mm		2 51	3 76	4 102	6 152	8 203	10 254	12 305	13.25 337	15.25 387	17.25 438		19.25 489	21.25 540	23.25 591	23.25 591			
	L	inch mm	14 356	17 432	22 559	26 660	31 787	33 838	35 889	39 991	43 1092	47 1194		55 1397	57 1448	61 1549	65 1651				
	H1	inch mm	6.93 176	9.72 247	10.87 276	14.29 363	14.29 363	16.77 426	21.57 548	23.54 598	25.51 648	29.13 740		31.89 810	34.06 865	36.22 920	36.22 920				
	H2	inch mm	4.69 119	5.79 147	6.77 172	9.84 250	12.52 318	14.65 372	17.09 434	19.06 484	21.02 534	23.23 590		25.91 658	27.99 711	30.16 766	30.16 766				
	Operation			Lever					Gear												

**Class 900**

**Carbon/Stainless Steel Ball Valves**

Split body, side entry design

**Fig.G-900SCTCS**

Full Bore

**Fig.G-900UTCS**

Full Bore

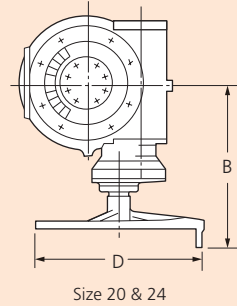
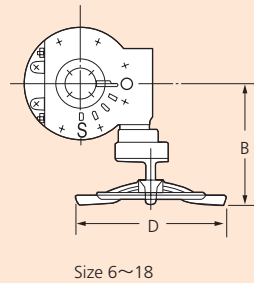
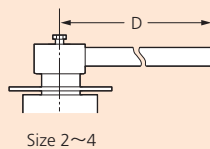
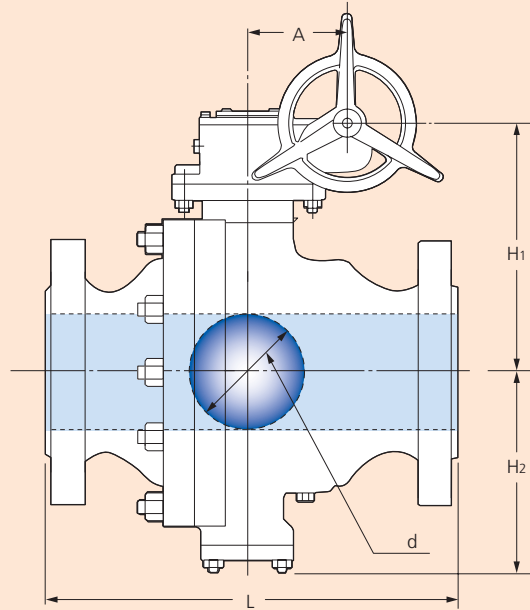

**Fig.(G-)900SCTCS / (G-)900UTCS**

	Nominal Size	2	3	4	6	8	10	12	14	16	18	20	22	24	26	28	30	32	34	36	
		inch	mm	inch	mm	inch	mm	inch	mm	inch	mm	inch	mm	inch	mm	inch	mm	inch	mm	inch	mm
Full Bore	Bore d	2	3	4	6	8	10	12	12.75	14.75	16.75	18.625		22.5							
		51	76	102	152	203	254	305	324	375	426	473		572							
	L	14.5	15	18	24	29	33	38	40.5	44.5	48	52		61							
		368	381	457	610	737	838	965	1029	1130	1219	1321		1549							
H1	inch	7.56	10.98	12.40	12.72	15.00	20.39	22.36	26.18	28.74	31.30	32.48		38.31							
	mm	192	279	315	323	381	518	568	665	730	795	825		973							
H2	inch	5.59	6.77	8.07	10.71	13.19	15.98	18.15	20.20	22.95	25.43	27.80		32.72							
	mm	142	172	205	272	335	406	461	513	583	646	706		831							
Operation		Lever					Gear														

**Class 900**

**Carbon/Stainless Steel Ball Valves**

Split body, side entry design

**Fig.G-900SCTCRS**

Reduced Bore

**Fig.G-900UTCRS**

Reduced Bore

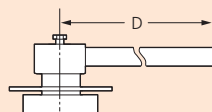
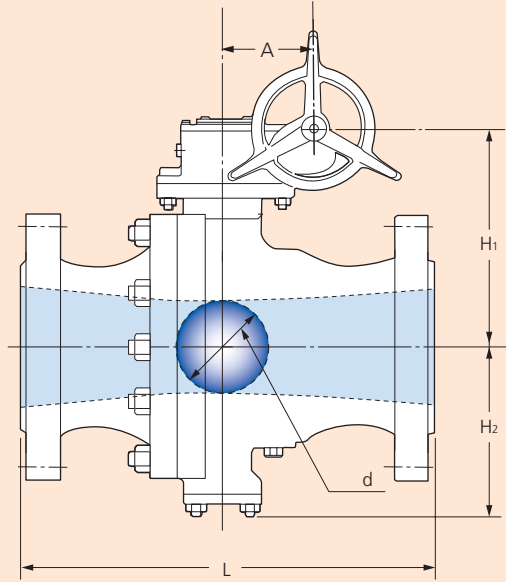

Size 3×2×3~6×4×6

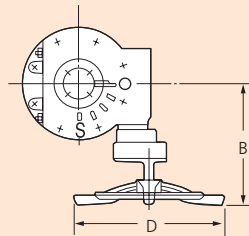

Size 8×6×8~20×18×20

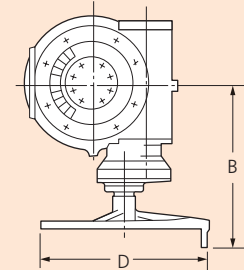

Size 24×20×24 only

**Fig.(G-)900SCTCRS / (G-)900UTCRS**

	Nominal Size	2	3	4	6	8	10	12	14	16	18	20	22	24	26	28	30	32	34	36	
		inch	3	4	6	8	10	12	14	16	18	20	22	24	26	28	30	32	34	36	
Reduced Bore	Bore d	inch	2	3	4	6	8	10	12	12.75	14.75	16.75		18.625							
		mm	51	76	102	152	203	254	305	324	375	426		473							
	L	inch	15	18	24	29	33	38	40.5	44.5	48	52		61							
		mm	381	457	610	737	838	965	1029	1130	1219	1321		1549							
H1	inch	7.56	10.98	12.40	12.72	15.00	20.39	22.36	26.18	28.74	31.30		32.48								
	mm	192	279	315	323	381	518	568	665	730	795		825								
H2	inch	5.59	6.77	8.07	10.71	13.19	15.98	18.15	20.20	22.95	25.43		27.80								
	mm	142	172	205	272	335	406	461	513	583	646		706								
Operation		Lever					Gear														



**Class 1500**

**Carbon/Stainless Steel Ball Valves**

Split body, side entry design

**Fig.G-1500SCTCS**

Full Bore

**Fig.G-1500UTCS**

Full Bore

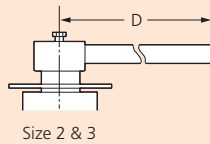
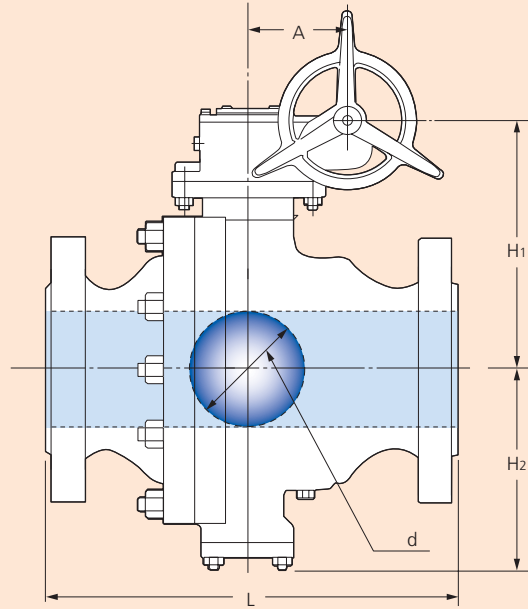

Size 2 & 3

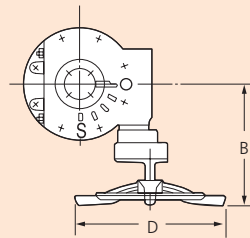

Size 4~14

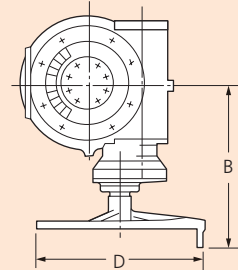

Size 16 & over

**Fig.(G-)1500SCTCS / (G-)1500UTCS**

	Nominal Size	2	3	4	6	8	10	12	14	16	18	20	22	24	26	28	30	32	34	36	
		inch	mm	inch	mm	inch	mm	inch	mm	inch	mm	inch	mm	inch	mm	inch	mm	inch	mm	inch	mm
Full Bore	Bore d	2	3	4	5.75	7.625	9.5	11.375	12.5	14.25	16.125	17.875									
		51	76	102	146	194	241	289	318	362	410	454									
	L	14.5	18.5	21.5	27.75	32.74	39	44.5	49.5	54.5	60.5	65.5									
		368	470	546	705	832	991	1130	1257	1384	1537	1664									
H1	inch	9.92	11.81	10.71	13.43	19.41	22.24	27.56	29.41	31.30	34.53	38.78									
	mm	252	300	272	341	493	565	700	747	795	877	985									
H2	inch	6.50	8.07	8.90	11.77	15.28	18.07	21.85	23.78	26.93	29.80	32.68									
	mm	165	205	226	299	388	459	555	604	684	757	830									
Operation		Lever			Gear																

**Class 1500**

**Carbon/Stainless Steel Ball Valves**

Split body, side entry design

**Fig.G-1500SCTCRS**

Reduced Bore

**Fig.G-1500UTCRS**

Reduced Bore

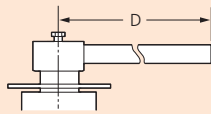
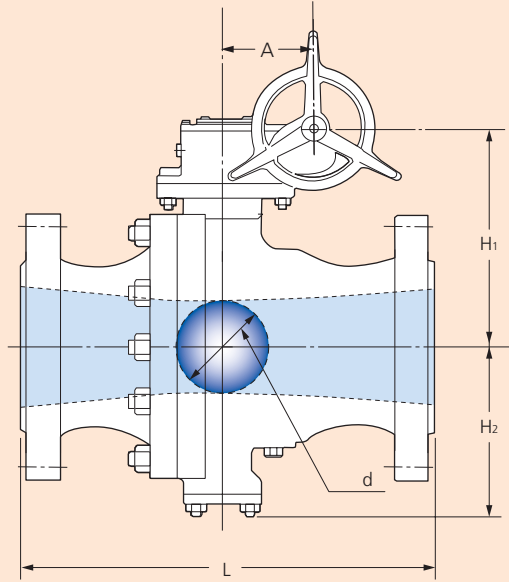

Size 3X2X3 & 4X3X4

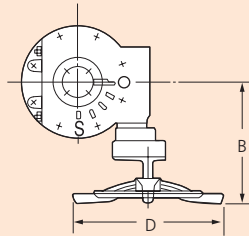

Size 6X4X6~16X14X16

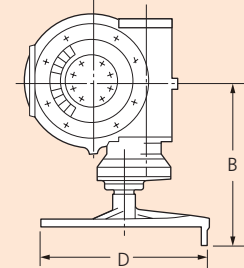

Size 18X16X18 & 20X18X20

**Fig.(G-)1500SCTCRS / (G-)1500UTCRS**

	Nominal Size	2	3	4	6	8	10	12	14	16	18	20	22	24	26	28	30	32	34	36	
		inch	3	4	6	8	10	12	14	16	18	20	22	24	26	28	30	32	34	36	
Reduced Bore	Bore d	inch	2	3	4	5.75	7.625	9.5	11.38	12.5	14.25	16.125									
		mm	51	76	102	146	194	241	289	318	362	410									
	L	inch	18.5	21.5	27.75	32.74	39	44.5	49.5	54.5	60.5	65.5									
		mm	470	546	705	832	991	1130	1257	1384	1537	1664									
H1	inch	9.92	11.81	10.71	13.42	19.41	22.24	27.56	29.41	31.30	34.53										
	mm	252	300	272	341	493	565	700	747	795	877										
H2	inch	6.50	8.07	8.90	11.77	15.28	18.07	21.85	23.78	26.93	29.80										
	mm	165	205	226	299	388	459	555	604	684	757										
Operation		Lever				Gear															

Exploded Diagram

This is typical construction of KITZ trunnion mounted ball design.  
For more details, contact KITZ agent or distributor

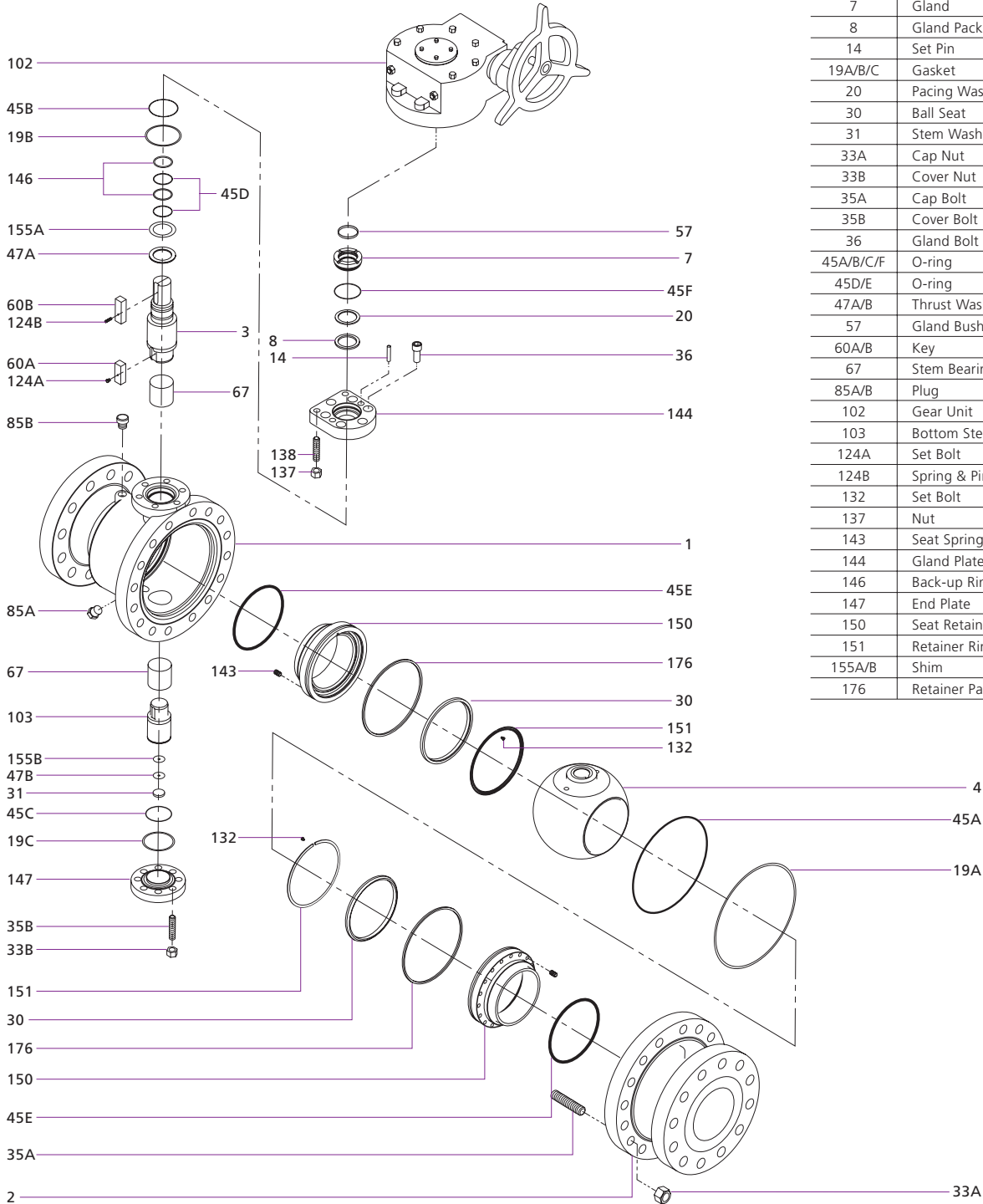

No	Name of Parts	Quantity
1	Body	1
2	Body Cap	1
3	Stem	1
4	Ball	1
7	Gland	1
8	Gland Packing	1
14	Set Pin	1set
19A/B/C	Gasket	1each
20	Pacing Washer	1
30	Ball Seat	2
31	Stem Washer	1
33A	Cap Nut	1set
33B	Cover Nut	1set
35A	Cap Bolt	1set
35B	Cover Bolt	1set
36	Gland Bolt	1set
45A/B/C/F	O-ring	1each
45D/E	O-ring	2each
47A/B	Thrust Washer	1each
57	Gland Bush	1
60A/B	Key	1each
67	Stem Bearing	2
85A/B	Plug	1each
102	Gear Unit	1
103	Bottom Stem	1
124A	Set Bolt	1
124B	Spring & Pin	1
132	Set Bolt	2
137	Nut	1set
143	Seat Spring	1set
144	Gland Plate	1
146	Back-up Ring	2
147	End Plate	1
150	Seat Retainer	2
151	Retainer Ring	2
155A/B	Shim	1set
176	Retainer Packing	2

### Material of Carbon Steel Valve (WCB)

No	Name of Parts	Materials	Specifications
1	Body	Carbon Steel	ASTM A216 Gr.WCB
2	Body Cap	Carbon Steel	ASTM A216 Gr.WCB
3	Stem	Stainless Steel	ASTM A276 Type 403 *1
4	Ball	Carbon Steel	ASTM A105 / A215 Gr.WCB *1
7	Gland	Stainless Steel	ASTM A276 Type 316 *1
8	Gland Packing	Flexible Graphite	
19A/B/C	Gasket	Flexible Graphite	
30	Ball Seat	Class 150,300 & 600 : Glass Filled PTFE + MoS2 Class 900 & 1500 : Nylon + Graphite	
33A	Cap Nut	Carbon Steel	ASTM A194 Gr.2H
36	Gland Bolt	Carbon Steel	ASTM A193 Gr.B7
45A/B/C/D/E/F	Oring	NBR	
67	Stem Bearing	Metal Backed PTFE	
103	Bottom Stem	Stainless Steel	ASTM A276 Type 403
144	Gland Plate	Carbon Steel	ASTM A105 *1
147	End Plate	Carbon Steel	ASTM A105
150	Seat Retainer	Carbon Steel	ASTM A105 *2
143	Seat Spring	Stainless Steel	A313 Type304
176	Retainer Packing	Flexible Graphite	
151	Retainer Ring	Stainless Steel	ASTM A240 Type 304

\*1 : Cr plated

\*2 : Zn plated

## Material of Stainless Steel Valve (CF8)

No	Name of Parts	Materials	Specifications
1	Body	Stainless Steel	ASTM A351 CF8
2	Body Cap	Stainless Steel	ASTM A351 CF8
3	Stem	Stainless Steel	ASTM A276 Type 304 *1
4	Ball	Stainless Steel	ASTM A351 CF8/A276 Type 304
7	Gland	Stainless Steel	ASTM A276 Type 316 *1
8	Gland Packing	Flexible Graphite	
19A/B/C	Gasket	Flexible Graphite	
30	Ball Seat	Class 150,300 & 600 : Glass Filled PTFE + MoS2 Class 900 & 1500 : Nylon + Graphite	
33A	Cap Nut	Stainless Steel	ASTM A194 Gr.8
36	Gland Bolt	Stainless Steel	ASTM A193 Gr.B8
45A/B/C/D/E/F	Oring	FKM	
67	Stem Bearing	Metal Backed PTFE	
103	Bottom Stem	Stainless Steel	ASTM A276 Type 304
144	Gland Plate	Stainless Steel	ASTM A276 Type 304 *1
147	End Plate	Stainless Steel	ASTM A276 Type 304
150	Seat Retainer	Stainless Steel	ASTM A276 Type 304
143	Seat Spring	Stainless Steel	A313 Type304
176	Retainer Packing	Flexible Graphite	
151	Retainer Ring	Stainless Steel	ASTM A240 Type 304

\*1 : Cr plated

## KITZ B Series Pneumatic Actuator

---

KITZ B Series Pneumatic Actuators are simply designed, assembled with minimized parts for trouble-free operation. The power transmission mechanism is separated from the cylinder. The design helps prevent air leakage and reduce chances to damage the scotch and yoke caused by supply air to achieve long service life.

### Type B (Double-Action)

---

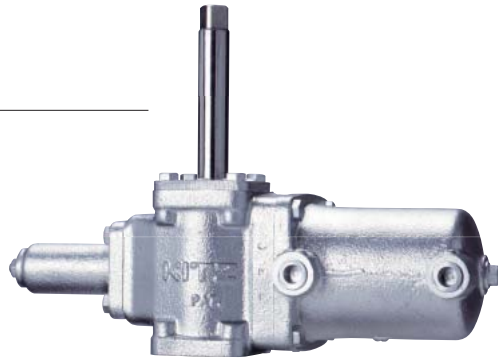

### Type BS (Spring-Return)

---



### Type BSW (Spring-Return with Manual Operation Device)

---



## CAUTION

Pressure-temperature ratings and other performance data published in this catalog have been developed from our design calculation, in-house testing, field reports provided by our customers and/or published official standards or specifications. They are good only to cover typical applications as a general guideline to users of KITZ products introduced in this catalog.

For any specific application, users are kindly requested to contact KITZ Corporation for technical advice, or to carry out their own study and evaluation for proving suitability of these products to such an application. Failure to follow this request could result in property damage and/or personal injury, for which we shall not be liable.

While this catalog has been compiled with the utmost care, we assume no responsibility for errors, impropriety or inadequacy. Any information provided in this catalog is subject to from-time-to-time change without notice for error rectification, product discontinuation, design modification, new product introduction or any other cause that KITZ Corporation considers necessary. This edition cancels all previous issues.

Read instruction manual carefully before use.

## NOTICE

If any products designated as strategic material in the Foreign Exchange and Foreign Trade Law, Cabinet Order Concerning Control of Export Trade, Cabinet order Concerning Control of Foreign Exchange and other related laws and ordinances ("Foreign Exchange Laws") are exported to any foreign country or countries, an export license issued by the Japanese Government will be required under the Foreign Exchange Laws.

Further, there may be cases where an export license issued by the government of the United States or other country will be required under the applicable export-related laws and ordinances in such relevant countries.

The contract shall become effective subject to that a relevant export license is obtained from the Japanese Government.

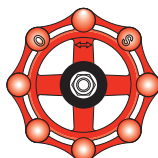

*A chrysanthemum-handle is a symbol of KITZ,  
the brand of valve reliability*

ISO 9001 certified since 1989

**KITZ**  
KITZ CORPORATION

1-10-1, Nakase, Mihama-ku, Chiba 261-8577, Japan  
International Sales Dept. Phone : 81-43-299-1730, 1732 and 1733  
Fax : 81-43-299-0121

— Distributed by —