

Ductile Iron Valves

JIS 10K/16K/20K
ASME Class 150/300



Contents

Class	Type	End Connection	Remarks	Code	mm	8	10	15	20	25	32	40	50	65	80	100	125	150	200	250	300	350	400	450	500	Page		
					inch	1/4	3/8	1/2	3/4	1	1 1/4	1 1/2	2	2 1/2	3	4	5	6	8	10	12	14	16	18	20			
10K	Globe	Threaded		10SJ		●	●	●	●	●	●	●	●	●												6		
	Globe	FF-flanged *1	PTFE disc	10SJBF			●	●	●	●	●	●	●	●												6		
	Globe	Threaded	PTFE disc	10SP			●	●	●	●	●	●	●													7		
	Globe	FF-flanged *1	PTFE disc	10SPBF			●	●	●	●	●	●	●													7		
	Globe	FF-flanged *1		10SPBAF				●	●	●	●	●	●													8		
	Globe	FF-flanged *1		10SPBOF									●	●	●	●	●	●	●	●	●	●	●	●	●	●	8	
	Globe	Threaded	PTFE disc	10SD		●	●	●	●	●	●	●	●	●	●												9	
	Globe	FF-flanged *1	PTFE disc	10SDBF			●	●	●	●	●	●	●	●	●												9	
	Globe	Threaded	LPG service	10SDL			●	●	●	●	●	●	●	●													10	
	Globe	FF-flanged *1	LPG service	10SDLBF			●	●	●	●	●	●	●	●													10	
	Globe	Threaded	PTFE disc	10SPD				●	●	●	●	●	●	●													11	
	Globe	FF-flanged *1	PTFE disc	10SPDBF				●	●	●	●	●	●	●													11	
	Globe	FF-flanged *1	PTFE disc	10SPDBOF									●	●	●	●	●	●	●	●	●						12	
	Bellows Seal Globe	FF-flanged *1		10SPBAWF				●	●	●	●	●															12	
	Bellows Seal Globe	FF-flanged *1		10SPBOWF				●	●	●	●	●	●	●	●	●	●	●	●	●	●							13
	Bellows Seal Globe	FF-flanged *1	PTFE disc	10SPDBOWF				●	●	●	●	●	●	●	●	●	●	●	●	●	●							13
	Gate	Threaded		10SMS				●	●	●	●	●	●														14	
	Gate	Threaded		10SMAS				●	●	●	●	●	●														14	
	Gate	FF-flanged *1		10SMBF				●	●	●	●	●	●														15	
	Gate	FF-flanged *1		10SMBOF									●	●	●	●	●	●	●	●	●	●	●	●	●	●	15	
	Lift Check	Threaded		10SF				●	●	●	●	●	●														16	
	Lift Check	FF-flanged *1		10SFBF				●	●	●	●	●	●														16	
	Lift Check	Threaded		10SN				●	●	●	●	●	●														17	
Swing Check	Threaded		10SOZ				●	●	●	●	●	●														17		
Lift Check	FF-flanged *1		10SNBF				●	●	●	●	●	●														18		
Swing Check	FF-flanged *1		10SRBF									●	●	●	●	●	●	●	●	●	●	●	●	●	●	18		
Strainer	Threaded	Gas service	10FDY		●	●	●	●	●	●	●	●	●	●	●											19		
Strainer	FF-flanged *1	Gas service	10FDYBF				●	●	●	●	●	●	●	●	●	●	●	●	●	●	●	●	●	●	●	19		
16K	Globe	Threaded		16SP			●	●	●	●	●	●														20		
	Globe	RF-flanged		16SPB			●	●	●	●	●	●														20		
	Globe	RF-flanged		16SPBO									●	●	●	●	●	●	●	●	●	●	●	●	●	21		
	Gate	Threaded		16SMS			●	●	●	●	●	●														21		
	Gate	RF-flanged		16SMB			●	●	●	●	●	●														22		
	Gate	RF-flanged		16SMBO								●	●	●	●	●	●	●	●	●	●	●	●	●	●	22		
	Lift Check	Threaded		16SF			●	●	●	●	●	●														23		
	Lift Check	RF-flanged		16SFB			●	●	●	●	●	●														23		
	Swing Check	RF-flanged		16SRB									●	●	●	●	●	●	●	●	●	●	●	●	●	24		
	Strainer	Threaded		16FDY			●	●	●	●	●	●	●													24		
	Strainer	RF-flanged		16FDYB			●	●	●	●	●	●	●	●	●	●	●	●	●	●	●	●	●	●	●	25		
20K	Globe	Threaded	Hard faced	20SY			●	●	●	●	●	●														25		
	Globe	RF-flanged	Hard faced	20SYB			●	●	●	●	●	●														26		
	Globe	RF-flanged	Hard faced	20SYBO									●	●	●	●	●	●	●	●						26		
	Globe	Threaded	Gas service	20SDL			●	●	●	●	●	●	●													27		
	Globe	RF-flanged	Gas service	20SDLB				●	●	●	●	●	●													27		
	Globe	RF-flanged	Gas service	20SDLBO									●	●	●	●	●	●	●	●	●					28		
	Bellows Seal Globe	RF-flanged		20SYBOW			●	●	●	●	●	●	●	●	●	●	●	●	●	●	●					28		
	Bellows Seal Globe	RF-flanged	PTFE disc	20SDBOW			●	●	●	●	●	●	●	●	●	●	●	●	●	●	●					29		
	Gate	Threaded		20SLS				●	●	●	●	●														29		
	Gate	RF-flanged		20SLB				●	●	●	●	●														30		
	Gate	RF-flanged		20SLBO								●	●	●	●	●	●	●	●	●	●	●	●	●	●	30		
	Lift Check	Threaded	Hard faced	20SN				●	●	●	●	●	●													31		
	Lift Check	RF-flanged	Hard faced	20SNB				●	●	●	●	●	●													31		
	Lift Check	RF-flanged	Gas service	20SNDB				●	●	●	●	●	●													32		
	Swing Check	RF-flanged		20SOB									●	●	●	●	●	●	●	●	●	●	●	●	●	32		
	Swing Check	RF-flanged	Gas service	20SODB					●		●	●	●	●	●	●	●	●	●	●	●					33		
	Strainer	Threaded	Gas service	20FDY			●	●	●	●	●	●	●													33		
	Strainer	RF-flanged	Gas service	20FDYB			●	●	●	●	●	●	●	●	●	●	●	●	●	●	●	●	●	●	●	34		

*1 RF-flanged ends가 옵션으로 사용가능 합니다. *2 Gear operation type.

Contents

Class	Type	End Connection	Remarks	Code	mm	8	10	15	20	25	32	40	50	65	80	100	125	150	200	250	300	350	400	450	Page
					inch	1/4	3/8	1/2	3/4	1	1 1/4	1 1/2	2	2 1/2	3	4	5	6	8	10	12	14	16	18	
150	Globe	RF-flanged		150SPB				●	●	●	●	●													34
	Globe	RF-flanged		150SPBO									●	●	●	●	●	●							35
	Globe	RF-flanged	PTFE disc	150SPDB				●	●	●	●	●													35
	Gate	RF-flanged		150SMBO								●	●	●	●	●	●	●	●	●	●	●	●	●	36
	Swing Check	RF-flanged		150SRB								●	●	●	●	●	●	●	●	●	●	●	●	●	36
300	Globe	RF-flanged	Hard faced	300SYB				●	●	●	●	●													37
	Globe	RF-flanged	Hard faced	300SYBO									●	●	●	●	●	●	●						37
	Gate	RF-flanged		300SLBO								●	●	●	●	●	●	●	●	●	●	●	●	●	38
	Swing Check	RF-flanged		300SOB								●	●	●	●	●	●	●	●	●	●	●	●	●	38
10K	Ball	FF-flanged *1		10STBF				●	●	●	●	●	●	●	●	●	●	●	●						39
	Ball	FF-flanged *1	Gas service	10STLBF				●	●	●	●	●	●	●	●	●	●	●	●	●					39
	Ball	3-way 4-seat		10STB4LAF								●	●	●	●	●									39
	Ball	3-way 4-seat		10STB4TAF								●	●	●	●	●									39
	Ball	3-way 4-seat		10STR4LAF													●	●	●						39
	Ball	3-way 4-seat		10STR4TAF													●	●	●						39
20K	Ball	Threaded		20ST				●	●	●	●	●	●												40
	Ball	Threaded	Gas service	20STL				●	●	●	●	●	●	△											40
	Ball	RF-flanged	Gas service	20STLB				●	●	●	●	●	●	●	●	●		●	●						40
400	Ball	Threaded	STZ		●	●	●	●	●	●	●	●													41
10K	Wafer Check	Wafer	Spring loaded	10SWZU								●	●	●	●	●	●	●	●	●	●	●	●	●	41
20K	Wafer Check	Wafer	Spring loaded	20SWZ								●	●	●	●	●	●	●	●	●	●	●	●	●	42
	Wafer Check	Wafer	Spring loaded	20SWZU								●	●	●	●	●	●	●	●	●	●	●	●	●	42

* 1 RF-flanged ends가 옵션으로 사용가능 합니다.
 △ 특별 주문 항목입니다.

해당 카탈로그에 소개된 제품은 모두 1989년 밸브업계 최초로 ISO 9001 인증을 받은 KITZ Corporation의 제품입니다.

What is Ductile Iron ?

밸브를 구성하는데 사용되는 철 성분은 Gray Iron(회주철), Ductile Iron(연성철) 그리고 Malleable Iron(가단철) 이렇게 세가지 종류가 있습니다. Gray Iron이 얇고 가는 플레이크형(flake-like) 분자구조를 가진 반면, Ductile Iron과 Malleable Iron은 구상흑연(Nodular Graphite) 성분을 가지고 있습니다. (오른쪽에 열거된 현미경사진에서도 참조할수 있습니다.)

Ductile Iron과 Malleable Iron이 가진 기계적성분(Mechanical Properties)은 Gray Iron의 기계적 성분보다 뛰어나며, 밸브산업에서 비싸게 사용되는 Cast Steel(주강)과 동일한 성분을 가지고 있습니다. 뿐만 아니라 우수한 주조성(Castability)과 가공성(Machinability)이 밸브원재료로서 적합성을 높이는데 기여합니다.

Ductile Iron은 Malleable Iron보다 우수한 기계적 성질을 가졌기 때문에 압력을 가하는 장치에 이용되는 밸브본체에 많이 사용됩니다. 예를들면, Ductile Iron의 항장력(tensile strength)이 Malleable Iron보다 20% 더 높고, 연성률(elongation)은 70-80% 더 좋습니다. 이러한 차이점은 구상흑연(Nodular Graphite)의 각기 다른 형성과정에서 생겨납니다.

KITZ Ductile Iron밸브는 JIS FCD-S 또는 ASTM A395의 기준에 따라 제작됩니다. Ductile Iron 밸브가 밸브시장에 도입된 역사는 짧지만 주강밸브(Cast Steel Valve)와 비교하였을 때 다양한 분야에서 적용이 가능하다는 점과 경제적인 측면 때문에 Ductile Iron 밸브의 수요는 꾸준히 증가하는 중입니다.

해당 카탈로그는 KITZ Corporation 에서 제작되는 Ductile Iron Valve와 Strainer에 관련된 사양(Specification), 원재료(Materials of construction) 및 외부치수(External dimension)에 관련된 내용을 제공합니다. 제품목록은 아래와 같습니다. :

- JIS 10K, 16K, & 20K Gate, Globe, & Check Valves
- JIS 10K & 20K Ball Valves
- JIS 10K, 16K, & 20K Strainers
- ASME 150 & 300 Gate, Globe, & Check Valves



Ductile iron

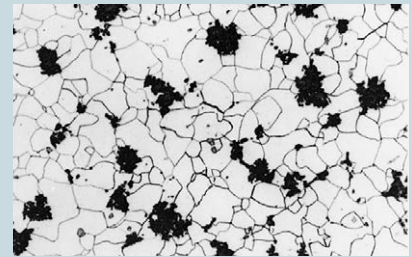

Malleable iron



Gray iron

Service Recommendation

기존의 Gray Iron Valve와 달리, Ductile Iron Valve는 고온 및 저온에도 견딜수 있는 기계적특성과 높은 항장력(tensile strength) 및 연성률(elongation)을 가졌습니다. 따라서 종종 Cast Iron Valve를 대신하여 아래의 분야에 관련해 사용하기를 추천합니다.

- 증기배관 (Piping for steam supply)
- 냉·난방 시스템 (Air conditioning and heating systems)
- 전반적인 고압가스 설비 (High-pressure gaseous service in general)
- 유독가스 배관 (Piping for poisonous gas service)

Iron Valve를 사용하는 고압가스설비의 압력범위는 경제부에 의해 규정되며 일본 무역과 산업은 하위 표를 따릅니다.

Valve material	Poisonous gas*	Inflammable gas	Other gas
Ductile iron (JIS FCD-S)		2.4MPa maximum -5°C to +350°C	
Ductile iron (JIS FCD400)	not recommended	1.6MPa maximum 0°C to +250°C	
Gray iron (JIS FC200)	not recommended		0.2MPa max. 0°C to +250°C

*Phosgene과 시안화수소(Hydrogen Cyanide)는 제외됩니다.

Material Specifications of JIS FCD-S

1. 화학 합성물 :

- 탄소 (Carbon) : 3.00% minimum
- 인 (Phosphorus) : 0.08% maximum
- 실리콘 (Silicon) : 2.50% maximum; however, 0.08% may be added for every decrease of 0.01% phosphor within the total maximum of 2.75%

2. 기계적 성질 :

- 항장력 (Tensile strength) : 412N/mm² minimum
- 항복 강도 (Yield strength) : 275N/mm² minimum
- 탄성률 (Elongation) : 18% minimum
- Brinell 경도 (Brinell hardness) : 143-187
- Charpy impact value :
 - a) for ambient temperature service ;
17N·m/cm² minimum in average of 3 test pieces.
15N·m/cm² minimum for the lowest impact value.
 - b) for -10°C or lower temperature service ;
15.3N·m/cm² minimum in average of 3 test pieces.
13.3N·m/cm² minimum for the lowest impact value.

Compared Mechanical Properties of JIS Materials

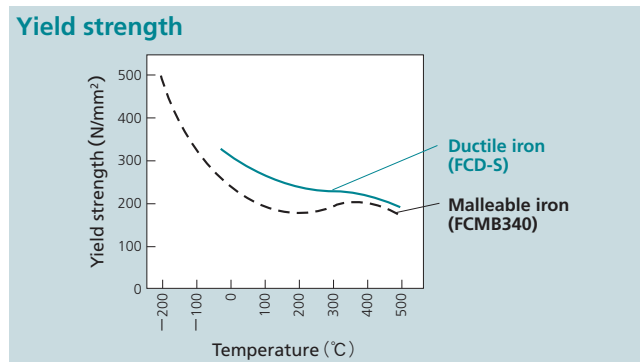
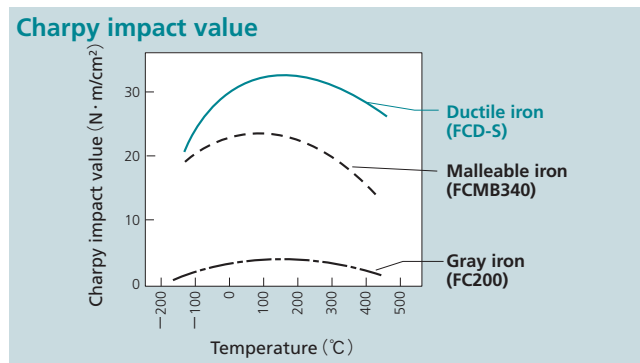
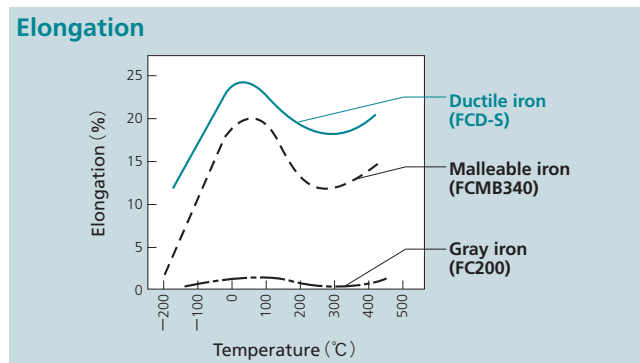
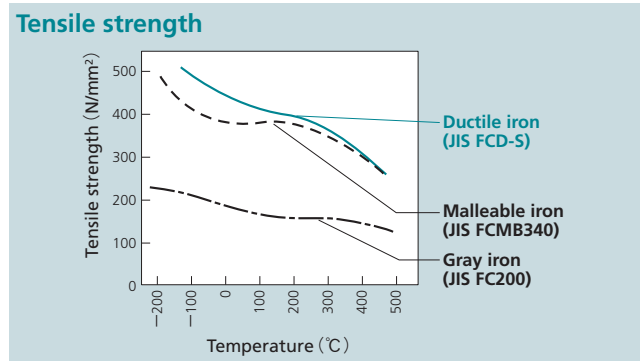

Abbreviated Design Description

- B.B. Bolted bonnet
- B.C. Bolted cover (or cap)
- S.B. Screwed bonnet
- S.C. Screwed cover (or cap)
- U.B. Union bonnet
- I.S. Inside screw
- O.S.Y. Outside screw & yoke

Design Specifications (자세한 내용은 다음 페이지를 참조하십시오.)

Class	JIS 10K/16K/20K	ASME 150/300
Pressure-temperature rating	5페이지 표를 참조하십시오.	
Face-to-face dimension	JIS B 2011, B 2002, or KITZ Std.	ASME B16. 10
End-to-end dimension	JIS B 2051 or KITZ Std.	—
End flange dimension	JIS B 2239	ASME B16. 5
End thread dimension	JIS B 0203	—
Shell wall thickness	KITZ 표준입니다. 그렇지 않을 경우 다음 페이지를 참조하십시오.	

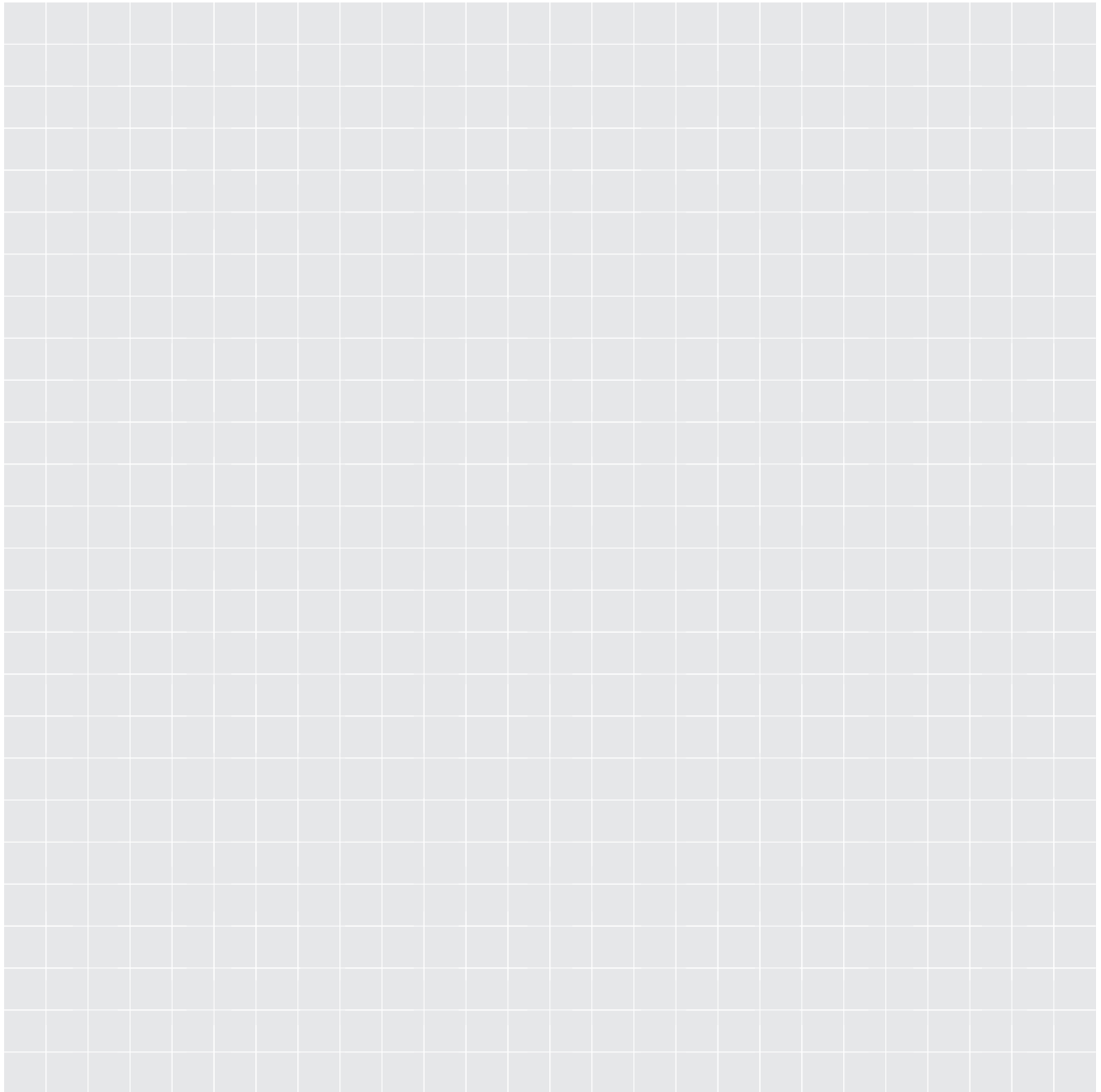

10SJBF 10SFBF
10SF

Pressure-Temperature Rating

10K Commercial Valves

10SJ 10SJBF 10SMS	Static water pressure at 120°C maximum	1.4MPa
10SF 10SFBF 10FDY *1 10SOZ	Steam, air, gas, oil, or pulsing water pressure at 220°C maximum	1.0MPa
10SD 10SDBF	Static water pressure at 120°C maximum	1.4MPa
(with PTFE disc)	Steam, air, gas, oil, or pulsing water pressure at 180°C maximum	1.0MPa
10SDL 10SDLBF	LPG at room temperature	0.20MPa
10SN 10SNBF	Static water pressure at 120°C maximum	1.4MPa
	Steam, air, gas, oil, or pulsing water pressure at 220°C maximum	1.2MPa

10K Valves

10SP 10SPBF 10SPBAF	Static water pressure at 120°C maximum	1.4MPa
10SPBOF 10SMAS 10SMBF	Steam, air, gas, oil, or pulsing water pressure at 220°C maximum	1.2MPa
10SMBOF 10SRBF 10FDYBF	Steam, air, gas, oil, or pulsing water pressure at 300°C	1.0MPa
10SPD 10SPDBF	Static water pressure at 120°C maximum	1.4MPa
10SPDBOF (with PTFE disc)	Steam, air, gas, oil, or pulsing water pressure at 180°C maximum	1.0MPa

16K Valves

16SP *2 16SPB *2 16SMS *2	Static water pressure at 120°C maximum	2.2MPa
16SMB *2 16SF *2 16SFB *2	Steam, air, gas, oil, or pulsing water pressure at 220°C maximum	2.0MPa
16FDY *2 16SMBO 16SPBO	Steam, air, gas, oil, or pulsing water pressure at 300°C	1.8MPa
16SRB 16FDYB	Steam, air, gas, oil, or pulsing water pressure at 350°C	1.6MPa

20K Valves

20SY *3 20SYB *3 20YBO *3	Static water pressure at 120°C maximum	2.8MPa
20SLS 20SLB 20SLBO	Steam, air, gas, oil, or pulsing water pressure at 220°C maximum	2.5MPa
20SN *3 20SNB *3 20SOB	Steam, air, gas, oil, or pulsing water pressure at 300°C	2.3MPa
20FDY 20FDYB	Steam, air, gas, oil, or pulsing water pressure at 350°C	2.0MPa
20SDL 20SDLB 20SDLBO	Gas at 80°C	2.4MPa
20SNDB 20SODB	Gas at 120°C	

Class 150 Valves

150SPB 150SPBO	-5°C ~ +38°C	1.73MPa
150SMBO 150SRB	149°C	1.48MPa
150SPDB *4	260°C	1.18MPa
(with PTFE disc)	343°C	0.86MPa

API 604 Class 150 밸브에 지정된 압력-온도 등급은 ASME Class 150 Ductile Iron 밸브에 적용됩니다.

Class 300 Valves

300SLBO	-5°C ~ +38°C	2.94MPa
300SYB *3	149°C	2.60MPa
300SYBO *3	260°C	2.28MPa
300SOB	350°C	2.04MPa

10K / 20K / Class 400 Ball Valves

10STBF	W.O.G. at 120°C maximum	1.4MPa
	W.O.G. at 140°C ~ 160°C maximum depending on size	1.0MPa
10STB4LAF 10STB4TAF	W.O.G. at 120°C maximum	1.00MPa
10STR4LAF 10STR4TAF	W.O.G. at 150°C maximum	0.40MPa
20ST	W.O.G. at 110°C maximum	2.8MPa
	W.O.G. at 140°C maximum	2.0MPa
ST (Class 400)	W.O.G. at room temperature	2.75MPa
	Saturated steam	0.98MPa
10STLBF	Gas at 80°C	1.2MPa
20STL 20STLB	Gas at 80°C	2.4MPa

* 1 200°C maximum * 2 220°C maximum

* 3 표시된 밸브는 고온용 서비스를 위하여 Disc와 Seat ring 표면에 Co-Cr-W ally Hard Facing처리를 하여 제공됩니다. Hard facing은 지정된 경우 여기에 열거된 다른 밸브를 사용할 수 있습니다.

* 4 180°C maximum

※KITZ Ductile Iron painting은 일반적인 서비스 조건에 적합합니다.

극심한 환경이나 높은 온도에서 사용되는 Painting의 경우, 서비스 환경에 따른 권장 사항을 문의하시길 바랍니다.

JIS 10K Globe Valve

10SJ

S.B.I.S. or U.B.I.S.

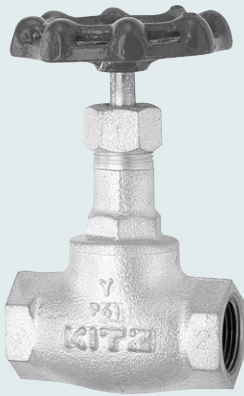

S.B.I.S. for 2" & smaller
U.B.I.S. for 2 1/2" & 3"

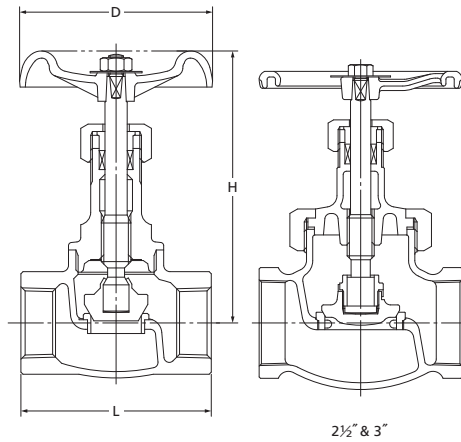

End to end : JIS B 2051 *
End connection : JIS B 0203
*KITZ Std. for 1/4", 3/8", 2 1/2", & 3"

120°C Static water..... 1.4MPa
220°C Steam, air, gas, oil..... 1.0MPa

●윤활 또는 유압 오일에 사용할 수 있습니다. 밸브가 열 전달 매체로 사용되는 경우 KITZ Corporation에 기술적 조언을 문의하십시오.

Materials

Parts	JIS material
Body	FCD-5
Bonnet	FCD-5
Stem	SUS420J2
Disc	403SS
Body seat ring	403SS
Gland	403SS (1/4" ~ 3/4" : SUS420J2)
Gland packing	Non-asbestos Packing
Packing nut	FCD-5
Handwheel	Ductile Iron
Wheel nut	Carbon Steel
Gasket	Stainless Foil Inserted Flexible Graphite (2 1/2" & over)
Bonnet ring	FCD-5 (2 1/2" & over)
Name plate	Aluminum

Dimensions

Size	mm										
	mm	8	10	15	20	25	32	40	50	65	80
	inch	1/4	3/8	1/2	3/4	1	1 1/4	1 1/2	2	2 1/2	3
L		50	55	65	80	90	105	120	140	180	200
H (open)		108	108	122	125	146	160	180	198	250	280
D		60	60	70	80	90	100	115	135	180	225

10K Globe Valve

10SJBF

S.B.I.S. or U.B.I.S.
FF-flanged

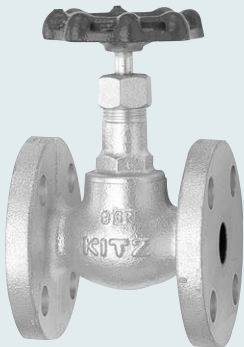

S.B.I.S. for 50 & smaller
U.B.I.S. for 65 & 80

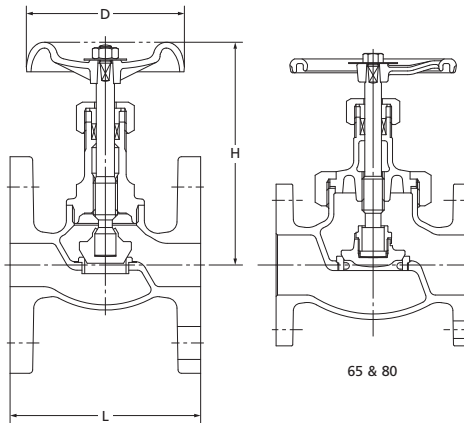

Face to face : JIS B 2011 *
End connection : JIS B 2239 10K
*KITZ Std. for 15

120°C Static water..... 1.4MPa
220°C Steam, air, gas, oil..... 1.0MPa

●윤활 또는 유압 오일에 사용할 수 있습니다. 밸브가 열 전달 매체로 사용되는 경우 KITZ Corporation에 기술적 조언을 문의하십시오.

Materials

Parts	JIS material
Body	FCD-5
Bonnet	FCD-5
Stem	SUS420J2
Disc	403SS
Body seat ring	403SS
Gland	SUS420J2 (32,65 & 80 : 403SS)
Gland packing	Non-asbestos Packing
Packing nut	FCD-5
Handwheel	Ductile Iron
Wheel nut	Carbon Steel
Gasket	Stainless Foil Inserted Flexible Graphite (65&80)
Bonnet ring	FCD-5 (65 & 80)
Name plate	Aluminum

Dimensions

Size	mm									
	mm	10	15	20	25	32	40	50	65	80
	inch	3/8	1/2	3/4	1	1 1/4	1 1/2	2	2 1/2	3
L		85	85	95	110	130	150	180	210	240
H (open)		108	122	125	146	160	180	198	250	280
D		60	70	80	90	100	115	135	180	225

NOTE : Flange의 크기는 44페이지를 참조하십시오. ※RF-flanged ends는 옵션으로 사용 가능합니다.

10K Globe Valve

10SP
U.B.I.S.

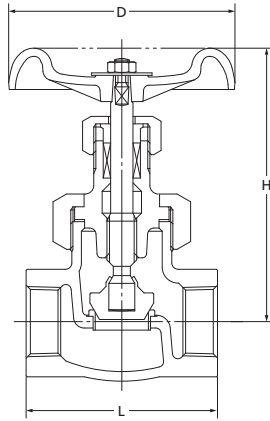

End to end : JV 4-4*
End connection : JIS B 0203
*KITZ Std. for 3/8"

120°C Static water.....1.4MPa
220°C Steam, air, gas, oil.....1.2MPa
300°C Steam, air, gas, oil.....1.0MPa

- 윤활 또는 유압 오일에 사용할 수 있습니다. 밸브가 열 전달 매체로 사용되는 경우 KITZ Corporation에 기술적 조언을 문의하십시오.
- 이 밸브에 Copper Gasket을 사용하면 암모니아 또는 Amine 화학 물질을 다루는 데에 사용할 수 없습니다.

Materials

Parts	JIS material
Body	FCD-S
Bonnet	FCD-S
Stem	SUS420J2
Disc	403SS
Body seat ring	403SS
Gland	SUS420J2 (1 1/4": 403SS)
Gland packing	Non-asbestos Packing
Packing nut	FCD-S
Handwheel	Ductile Iron
Wheel nut	Carbon Steel
Bonnet ring	FCD-S
Gasket	Tough Pitch Copper
Name plate	Aluminum

Dimensions

Size	mm							
	mm	10	15	20	25	32	40	50
	inch	3/8	1/2	3/4	1	1 1/4	1 1/2	2
L		64	70	80	90	110	120	140
H (open)		107	125	125	145	162	180	198
D		60	80	80	100	115	115	135

10K Globe Valve

10SPBF
U.B.I.S.
FF-flanged

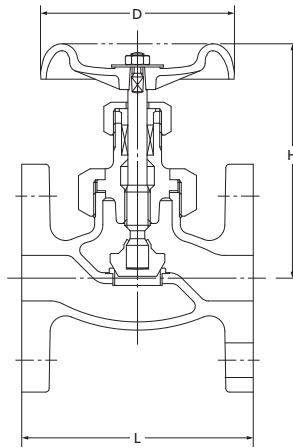

Face to face : JIS B 2002*
End connection : JIS B 2239 10K
*KITZ Std. for 10

120°C Static water.....1.4MPa
220°C Steam, air, gas, oil.....1.2MPa
300°C Steam, air, gas, oil.....1.0MPa

- 윤활 또는 유압 오일에 사용할 수 있습니다. 밸브가 열 전달 매체로 사용되는 경우 KITZ Corporation에 기술적 조언을 문의하십시오.
- 이 밸브에 Copper Gasket을 사용하면 암모니아 또는 Amine 화학 물질을 다루는 데에 사용할 수 없습니다.

Materials

Parts	JIS material
Body	FCD-S
Bonnet	FCD-S
Stem	SUS420J2
Disc	403SS
Body seat ring	403SS
Gland	SUS420J5(10~25,40,50) 403SS(32 only)
Gland packing	Non-asbestos Packing
Handwheel	Ductile Iron
Wheel nut	Carbon Steel
Bonnet ring	FCD-S
Gasket	Tough Pitch Copper
Name plate	Aluminum

Dimensions

Size	mm							
	mm	10	15	20	25	32	40	50
	inch	3/8	1/2	3/4	1	1 1/4	1 1/2	2
L		108	108	117	127	140	165	203
H (open)		107	125	125	145	162	180	198
D		60	80	80	100	115	115	135

NOTE : Flange의 크기는 44페이지를 참조하십시오. ※RF-flanged ends는 옵션으로 사용 가능합니다.

10K Globe Valve

10SPBAF
B.B.I.S.
FF-flanged

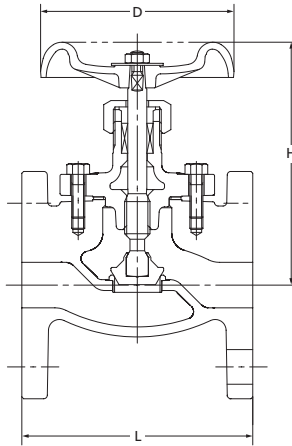

Face to face : JIS B 2051
End connection : JIS B 2239 10K

120°C Static water.....1.4MPa
220°C Steam, air, gas, oil.....1.2MPa
300°C Steam, air, gas, oil.....1.0MPa

●윤활 또는 유압 오일에 사용할 수 있습니다. 밸브가 열 전달 매체로 사용되는 경우 KITZ Corporation에 기술적 조언을 문의하십시오.

Materials

Parts	JIS material
Body	FCD-S
Bonnet	FCD-S
Stem	SUS420J2
Disc	403SS
Body seat ring	403SS
Gland	SUS420J2(32 : 403SS)
Gland packing	Non-asbestos Packing
Packing nut	FCD-S
Handwheel	Ductile Iron
Wheel nut	Carbon Steel
Bonnet bolt	Carbon Steel
Gasket	Stainless Foil Inserted Flexible Graphite
Name plate	Aluminum

Dimensions

Size	mm	15	20	25	32	40	50	mm
	inch	1/2	3/4	1	1 1/4	1 1/2	2	
L		108	117	127	140	165	203	
H (open)		123.5	124	146	161.5	179	197.5	
D		80	80	100	115	115	135	

NOTE : Flange의 크기는 44페이지를 참조하십시오. ※RF-flanged ends는 옵션으로 사용 가능합니다.

10K Globe Valve

10SPBOF
B.B.O.S.Y.
FF-flanged

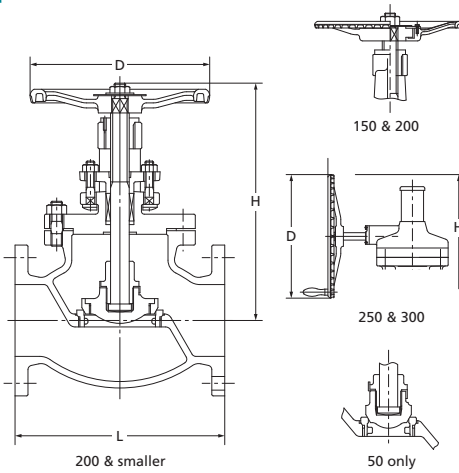

Face to face : JIS B 2002
End connection : JIS B 2239 10K

120°C Static water.....1.4MPa
220°C Steam, air, gas, oil.....1.2MPa
300°C Steam, air, gas, oil.....1.0MPa

●윤활 또는 유압 오일에 사용할 수 있습니다. 밸브가 열 전달 매체로 사용되는 경우 KITZ Corporation에 기술적 조언을 문의하십시오.
●볼트 재질은 225°C를 넘는 고온용으로 교체됩니다. 자세한 내용은 KITZ Corporation으로 문의하시기 바랍니다.

Materials

Parts	JIS material
Body	FCD-S
Bonnet	FCD-S
Stem	403SS
Disc	FCD-S (50 : 403SS)
Disc seat ring	403SS
Body seat ring	403SS
Lock nut	FCD-S
Gland	FCD-S
Gland packing	Non-asbestos Packing
Handwheel *	Ductile Iron
Wheel nut *	Carbon Steel
Packing washer	403SS
Bonnet bolt/nut	Carbon Steel
Gland bolt/nut	Carbon Steel
Gasket	Stainless Foil Inserted Flexible Graphite
Name plate	Aluminum
Yoke bush *	High Tension Brass

* 200 & smaller

Dimensions

Size	mm	50	65	80	100	125	150	200	250	300	mm
	inch	2	2 1/2	3	4	5	6	8	10	12	
L		203	216	241	292	356	406	495	622	698	
H (open)		302	317	356	377	460	524	585	880	943	
D		200	225	250	250	300	350	400	360	360	

NOTE : Flange의 크기는 44페이지를 참조하십시오. ※RF-flanged ends는 옵션으로 사용 가능합니다.

10K Globe Valve

10SD

S.B.I.S. or U.B.I.S.

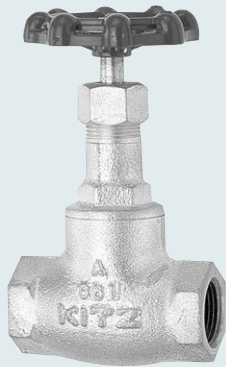

Reinforced PTFE disc
S.B.I.S. for 2" & smaller
U.B.I.S. for 2 1/2" & 3"

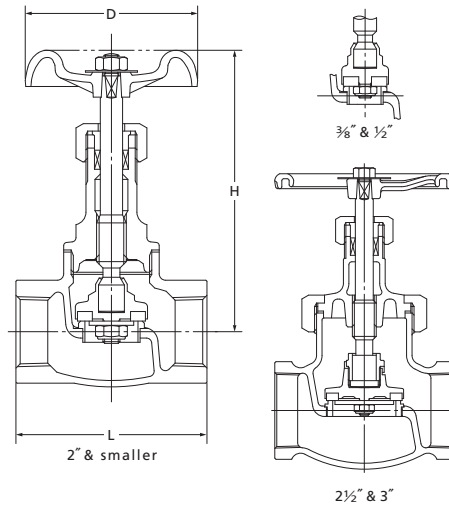

End to end : JIS B 2051*
End connection : JIS B 0203
*KITZ Std. for 1/4", 3/8", 2 1/2", & 3"

120°C Static water.....1.4MPa
180°C Steam, air, gas, oil..... 1.0MPa

- 윤활 또는 유압 오일에 사용할 수 있습니다. 밸브가 열 전달 매체로 사용되는 경우 KITZ Corporation에 기술적 조언을 문의하십시오.
- 이 밸브에 Copper Gasket을 사용하면 암모니아 또는 Amine 화학 물질을 다루는 데에 사용할 수 없습니다.

Materials

Parts	JIS material
Body	FCD-S
Bonnet	FCD-S
Stem	SUS420J2
Disc	G/F PTFE
Disc holder	SCS1 (2 1/2" & 3" : 403SS)
Disc nut	SS400
Body seat ring	403SS
Gland	403SS (1/4" ~ 1", 1 1/2" & 2" : SUS420J2)
Gland packing	Non-asbestos Packing
Packing nut	FCD-S
Handwheel	Ductile Iron
Wheel nut	Carbon Steel
Gasket	Tough Pitch Copper (2 1/2" & 3" : Non-asbestos Sheet)
Name plate	Aluminum

Dimensions

Size	mm									
	8	10	15	20	25	32	40	50	65	80
L	50	55	65	80	90	105	120	140	180	200
H (open)	108	108	123	123	144	159	178	197	262	295
D	60	60	70	80	90	100	115	135	180	225

JIS 10K Globe Valve

10SDBF

S.B.I.S. or U.B.I.S.
FF-flanged



Reinforced PTFE disc
S.B.I.S. for 50 & smaller
U.B.I.S. for 65 & 80

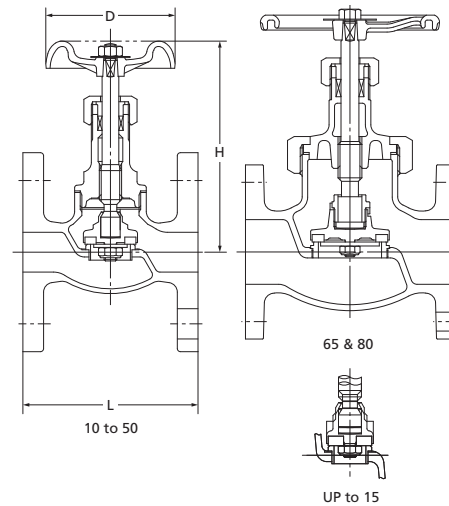

Face to face : JIS B 2011*
End connection : JIS B 2239 10K
*KITZ Std. for 10

120°C Static water.....1.4MPa
180°C Steam, air, gas, oil..... 1.0MPa

- 윤활 또는 유압 오일에 사용할 수 있습니다. 밸브가 열 전달 매체로 사용되는 경우 KITZ Corporation에 기술적 조언을 문의하십시오.
- 이 밸브에 Copper Gasket을 사용하면 암모니아 또는 Amine 화학 물질을 다루는 데에 사용할 수 없습니다.

Materials

Parts	JIS material
Body	FCD-S
Bonnet	FCD-S
Stem	SUS420J2
Disc	G/F PTFE
Disc holder	SCS1 (65 & 80 : 403SS)
Disc nut	SS400
Body seat ring	403SS
Gland	403SS (15 & 20 : SUS420J2)
Gland packing	Non-asbestos Packing
Packing nut	FCD-S
Handwheel	Ductile Iron
Wheel nut	Carbon Steel
Gasket	Tough Pitch Copper (65 & 80 : Non-asbestos Sheet)
Bonnet ring	FCD-S
Name plate	Aluminum

Dimensions

Size	mm									
	10	15	20	25	32	40	50	65	80	
L	85	85	95	110	130	150	180	210	240	
H (open)	108	123	123	144	159	178	197	262	295	
D	60	70	80	90	100	115	135	180	225	

NOTE : Flange의 크기는 44페이지를 참조하십시오. *RF-flanged ends는 옵션으로 사용 가능합니다.

10K Globe Valve for LPG Service

10SDL
S.B.I.S.

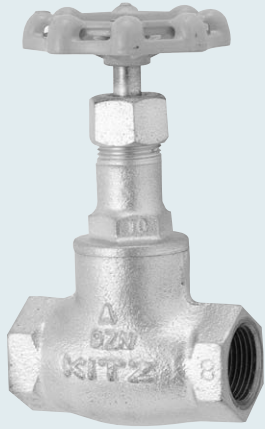

Reinforced PTFE disc for low-pressure gas service

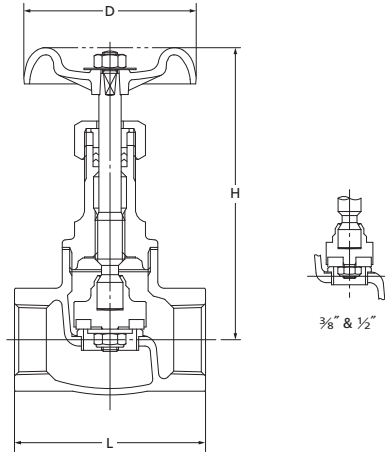

End to end : JIS B 2051*
End connection : JIS B 0203
*KITZ Std. for 3/8"

LPG at room temperature 0.20MPa

● 이 밸브에 Copper Gasket을 사용하면 암모니아 또는 Amine 화학 물질을 다루는 데에 사용할 수 없습니다.

Materials

Parts	JIS material
Body	FCD-5
Bonnet	FCD-5
Stem	SUS420J2
Disc	G/F PTFE
Disc holder	SCS1
Disc nut	SS400
Body seat ring	403SS
Gland	403SS (3/8" ~ 3/4" : SUS420J2)
Gland packing	NBR
Packing nut	FCD-5
Handwheel	Aluminum Die-cast (3/8" ~ 3/4" : Zinc Die-cast)
Wheel nut	Carbon Steel
Gasket	Tough Pitch Copper
Name plate	Aluminum

Dimensions

Size	mm							
	mm	10	15	20	25	32	40	50
	inch	3/8	1/2	3/4	1	1 1/4	1 1/2	2
L		55	65	80	90	105	120	140
H (open)		112	122	130	149	169	187	205
D		55	60	70	80	90	100	115

10K Globe Valve for LPG Service

10SDLBF
S.B.I.S.
FF-flanged



Reinforced PTFE disc for low pressure gas service

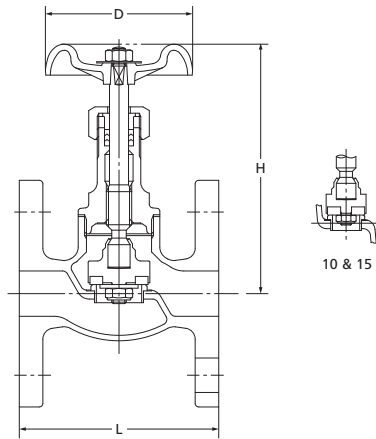

Face to face : JIS B 2011*
End connection : JIS B 2239 10K
*KITZ Std. for 10

LPG at room temperature 0.20MPa

● 이 밸브에 Copper Gasket을 사용하면 암모니아 또는 Amine 화학 물질을 다루는 데에 사용할 수 없습니다.

Materials

Parts	JIS material
Body	FCD-5
Bonnet	FCD-5
Stem	SUS420J2
Disc	G/F PTFE
Disc holder	SCS1
Disc nut	SS400
Body seat ring	403SS
Gland	403SS (15 & 20 : SUS420J2)
Gland packing	NBR
Packing nut	FCD-5
Handwheel	Zinc Die-cast (25 ~ 50 : Aluminum Die-cast)
Wheel nut	Carbon Steel
Gasket	Tough Pitch Copper
Name plate	Aluminum

Dimensions

Size	mm							
	mm	10	15	20	25	32	40	50
	inch	3/8	1/2	3/4	1	1 1/4	1 1/2	2
L		85	85	95	110	130	150	180
H (open)		112	122	130	149	169	187	205
D		55	60	70	80	90	100	115

NOTE : Flange의 크기는 44페이지를 참조하십시오. * RF-flanged ends는 옵션으로 사용 가능합니다.

10K Globe Valve

10SPD
U.B.I.S.

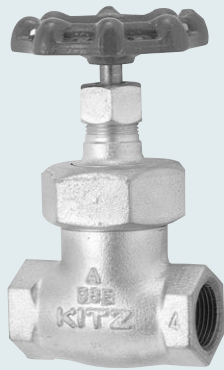

Reinforced PTFE disc

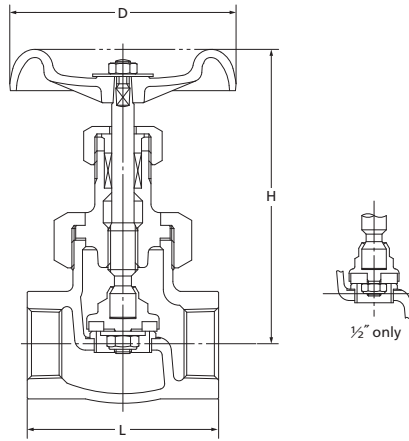

End to end : JV 4-4
End connection : JIS B 0203

120°C Static water..... 1.4MPa
180°C Steam, air, gas, oil..... 1.0MPa

- 윤활 또는 유압 오일에 사용할 수 있습니다. 밸브가 열 전달 매체로 사용되는 경우 KITZ Corporation에 기술적 조언을 문의하십시오.
- 이 밸브에 Copper Gasket을 사용하면 암모니아 또는 Amine 화학 물질을 다루는 데에 사용할 수 없습니다.

Materials

Parts	JIS material
Body	FCD-S
Bonnet	FCD-S
Stem	SUS 420J2
Disc	G/F PTFE
Gland	SUS420J2 (1 1/4" : 403SS)
Gland packing	Non-asbestos Packing
Packing nut	FCD-S
Handwheel	Ductile Iron
Bonnet ring	FCD-S
Disc holder	SCS1
Disc nut	SS400
Gasket	Tough Pitch Copper
Body seat ring	403SS
Name plate	Aluminum

Dimensions

Size	mm						
	mm	15	20	25	32	40	50
	inch	1/2	3/4	1	1 1/4	1 1/2	2
L		70	80	90	110	120	140
H (open)		125	125	146	162	180	198
D		80	80	100	115	115	135

10K Globe Valve

10SPDBF
U.B.I.S.
FF-flanged



Reinforced PTFE disc

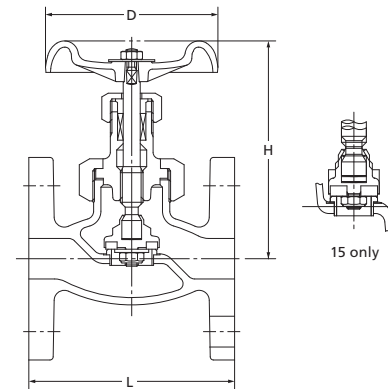

Face to face : JIS B 2002
End connection : JIS B 2239 10K

120°C Static water..... 1.4MPa
180°C Steam, air, gas, oil..... 1.0MPa

- 윤활 또는 유압 오일에 사용할 수 있습니다. 밸브가 열 전달 매체로 사용되는 경우 KITZ Corporation에 기술적 조언을 문의하십시오.
- 이 밸브에 Copper Gasket을 사용하면 암모니아 또는 Amine 화학 물질을 다루는 데에 사용할 수 없습니다.

Materials

Parts	JIS material
Body	FCD-S
Bonnet	FCD-S
Stem	SUS420J2
Disc	G/F PTFE
Gland	403SS
Gland packing	Non-asbestos Packing
Packing nut	FCD-S
Handwheel	Ductile Iron
Bonnet ring	FCD-S
Disc holder	SCS1
Disc nut	SS400
Gasket	Tough Pitch Copper
Body seat ring	403SS
Name plate	Aluminum

Dimensions

Size	mm						
	mm	15	20	25	32	40	50
	inch	1/2	3/4	1	1 1/4	1 1/2	2
L		108	117	127	140	165	203
H (open)		125	125	145	162	180	198
D		80	80	100	115	115	135

NOTE : Flange의 크기는 44페이지를 참조하십시오. *RF-flanged ends는 옵션으로 사용 가능합니다.

10K Globe Valve

10SPDBOF
B.B.O.S.Y.
FF-flanged



Reinforced PTFE disc

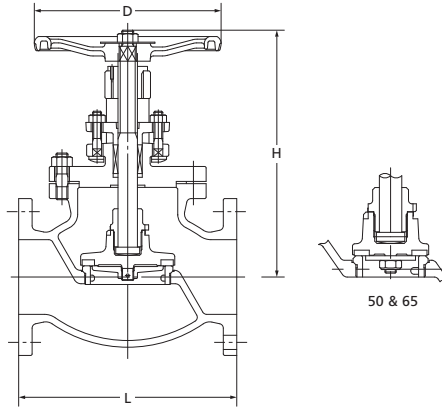

Face to face : JIS B 2002
End connection : JIS B 2239 10K

120°C Static water..... 1.4MPa
180°C Steam, air, gas, oil..... 1.0MPa

●유탄 또는 유압 오일에 사용할 수 있습니다. 밸브가 열 전달 매체로 사용되는 경우 KITZ Corporation에 기술적 조언을 문의하십시오.

Materials

Parts	JIS material
Body	FCD-S
Bonnet	FCD-S
Stem	403SS
Disc	G/F PTFE
Gland	FCD-S
Gland packing	Non-asbestos Packing
Handwheel	Ductile Iron
Disc holder	403SS
Disc nut	SCS13A (50 & 65 : S5400)
Gasket	Non-asbestos Sheet
Body seat ring	403SS
Name plate	Aluminum

Dimensions

Size	mm							
	mm	50	65	80	100	125	150	200
	inch	2	2½	3	4	5	6	8
L		203	216	241	292	356	406	495
H (open)		302	317	356	377	460	527	600
D		200	225	250	250	300	350	400

NOTE : Flange의 크기는 44페이지를 참조하십시오. ※RF-flanged ends는 옵션으로 사용 가능합니다.

10K Bellows Seal Globe Valve

10SPBAWF
B.B.I.S
FF-flanged

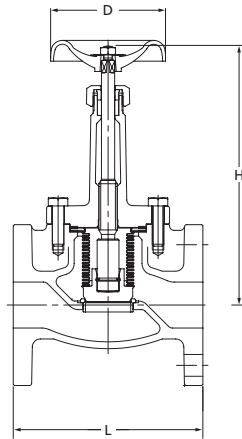
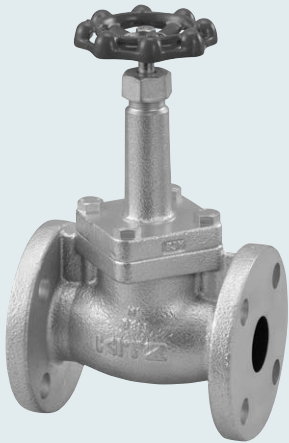

F-F dimension : JIS B2002
End flanges : JIS B2239 10K

120°C Static water..... 1.4MPa
300°C Steam, air, gas, oil..... 1.0MPa

●유탄 또는 유압 오일에 사용할 수 있습니다. 밸브가 열 전달 매체로 사용되는 경우 KITZ Corporation에 기술적 조언을 문의하십시오.

Materials

Parts	JIS material
Body	FCD-S
Bonnet	FCD-S
Stem	SUS420J2
Disc	403SS
Gland	SUS420J2 (32&40:403SS)
Gland packing	Flexible Graphite Braided Packing
Handwheel	Ductile Iron
Bonnet bolt/nut	Carbon Steel
Bellows	316LSS
Bellows holder	403SS
Body seat ring	403SS
Name plate	Aluminum

Dimensions

Size	mm					
	mm	15	20	25	32	40
	inch	½	¾	1	1¼	1½
L		108	117	127	140	165
H (open)		163	163	187	242	242
D		80	80	80	100	100

10K Bellows Seal Globe Valve

10SPBOWF
B.B.O.S.Y
FF-flanged

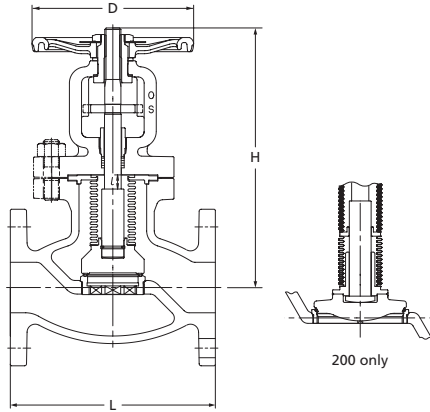

Face to face : JIS B2002
End connection : JIS B2239 10K

120°C Static water 1.4MPa
300°C Steam, air, gas, oil..... 1.0MPa

●윤활 또는 유압 오일에 사용할 수 있습니다. 밸브가 열 전달 매체로 사용되는 경우 KITZ Corporation에 기술적 조언을 문의하십시오.

Materials

Parts	JIS material
Body	FCD-S
Bonnet	FCD-S
Stem	403SS
Disc	304SS + HF *
Gland	403SS
Gland packing	Flexible Graphite
Handwheel	Ductile Iron
Bonnet bolt/nut	Carbon Steel
Bellows	316LSS
Bellows holder	304SS
Body seat ring	SCS13A + HF*(15 ~ 50) 304SS + HF*(65 ~ 150) 403SS + HF*(200)
Name plate	Aluminum

* Hard-faced with Co-Cr-W alloy

Dimensions

Size	mm											
	15	20	25	32	40	50	65	80	100	125	150	200
	1/2	3/4	1	1 1/4	1 1/2	2	2 1/2	3	4	5	6	8
L	108	117	127	140	165	203	216	241	292	356	406	495
H	184	184	190	238	238	271	285	395	432	529	586	749
D	90	90	100	140	140	160	180	250	300	350	400	450

10K Bellows Seal Globe Valve

10SPDBOWF
B.B.O.S.Y
FF-flanged



Reinforced PTFE disc

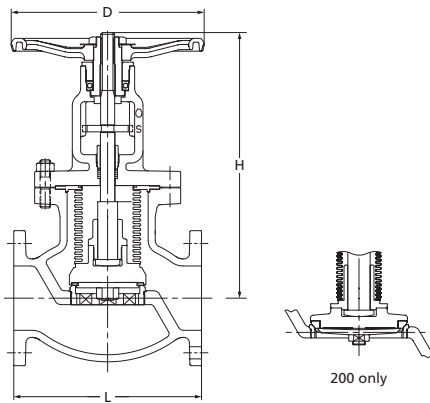

Face to face : JIS B2002
End connection : JIS B2239 10K

120°C Static water 1.4MPa
180°C Steam, air, gas, oil..... 1.0MPa

●윤활 또는 유압 오일에 사용할 수 있습니다. 밸브가 열 전달 매체로 사용되는 경우 KITZ Corporation에 기술적 조언을 문의하십시오.

Materials

Parts	JIS material
Body	FCD-S
Bonnet	FCD-S
Stem	403SS
Disc	G/F PTFE
Gland	403SS
Gland packing	Flexible Graphite
Handwheel	Ductile Iron
Bonnet bolt/nut	Carbon Steel
Bellows	316LSS
Bellows holder	304SS
Body seat ring	304SS / SCS13A(200 : 403SS)
Name plate	Aluminum

Dimensions

Size	mm											
	15	20	25	32	40	50	65	80	100	125	150	200
	1/2	3/4	1	1 1/4	1 1/2	2	2 1/2	3	4	5	6	8
L	108	117	127	140	165	203	216	241	292	356	406	495
H	184	184	190	238	238	271	305	395	432	529	586	749
D	90	90	100	140	140	160	180	250	300	350	400	450

JIS 10K Gate Valve

10SMS
S.B.I.S.

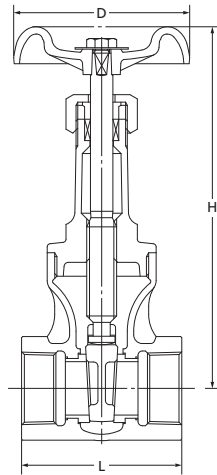

End to end : JIS B 2051
End connection : JIS B 0203

120°C Static water..... 1.4MPa
220°C Steam, air, gas, oil..... 1.0MPa

●윤활 또는 유압 오일에 사용할 수 있습니다. 밸브가 열 전달 매체로 사용되는 경우 KITZ Corporation에 기술적 조건을 문의하십시오.

Materials

Parts	JIS material
Body	FCD-S
Bonnet	FCD-S
Stem	SUS420J2
Disc	SCS1
Body seat ring	403SS
Gland	SUS420J2 (1¼": 403SS)
Gland packing	Non-asbestos Packing
Packing nut	FCD-S
Handwheel	Ductile Iron
Wheel nut	Carbon Steel
Name plate	Aluminum

Dimensions

Size	mm						
	mm	15	20	25	32	40	50
	inch	½	¾	1	1¼	1½	2
L		60	70	75	85	95	105
H (open)		150	171	198	233	274	318
D		60	70	80	90	100	115

10K Gate Valve

10SMAS
B.B.I.S.

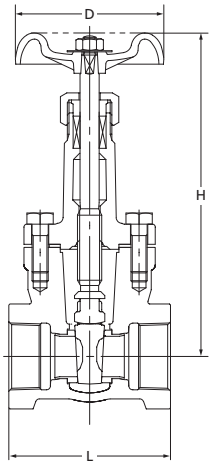
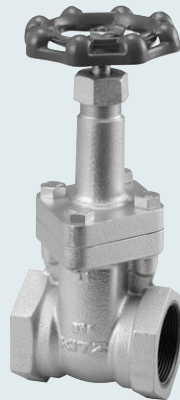

End to end : JIS B 2051
End connection : JIS B 0203

120°C Static water..... 1.4MPa
220°C Steam, air, gas, oil..... 1.2MPa
300°C Steam, air, gas, oil..... 1.0MPa

●윤활 또는 유압 오일에 사용할 수 있습니다. 밸브가 열 전달 매체로 사용되는 경우 KITZ Corporation에 기술적 조건을 문의하십시오.

Materials

Parts	JIS material
Body	FCD-S
Bonnet	FCD-S
Stem	SUS420J2
Disc	SCS1
Body seat ring	403SS
Gland	SUS420J2(1½": 403SS)
Gland packing	Non-asbestos Packing
Packing nut	FCD-S
Handwheel	Ductile Iron
Wheel nut	Carbon Steel
Bonnet bolt	Carbon Steel
Gasket	Non-asbestos Sheet
Name plate	Aluminum

Dimensions

Size	mm						
	mm	15	20	25	32	40	50
	inch	½	¾	1	1¼	1½	2
L		65	75	80	90	100	110
H (open)		161	162	184.5	215	250	285
D		70	70	80	90	110	115

10K Gate Valve

10SMBF
B.B.I.S.
FF-flanged

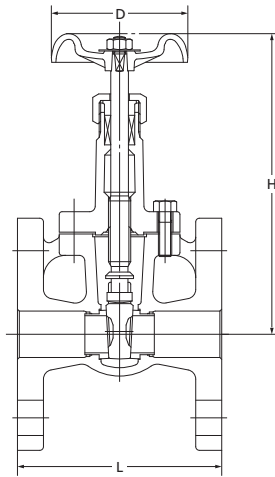
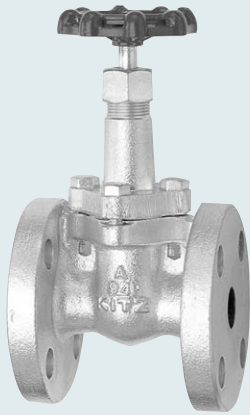

Face to face : JV4-4
End connection : JIS B 2239 10K

120°C Static water..... 1.4MPa
220°C Steam, air, gas, oil..... 1.2MPa
300°C Steam, air, gas, oil..... 1.0MPa

●윤활 또는 유압 오일에 사용할 수 있습니다. 밸브가 열 전달 매체로 사용되는 경우 KITZ Corporation에 기술적 조언을 문의하십시오.

Materials

Parts	JIS material
Body	FCD-5
Bonnet	FCD-5
Stem	SUS420J2
Disc	SCS1
Body seat ring	403SS
Gland	SUS420J2(1 1/2" : 403SS)
Gland packing	Non-asbestos Packing
Handwheel	Ductile Iron
Bonnet bolt	Carbon Steel
Gasket	Stainless Foil Inserted Flexible Graphite
Name plate	Aluminum

Dimensions

Size	mm						
	mm	15	20	25	32	40	50
	inch	1/2	3/4	1	1 1/4	1 1/2	2
L		90	100	110	120	130	140
H (open)		164	165	188	219	253	285
D		70	70	80	90	100	115

NOTE : Flange의 크기는 44페이지를 참조하십시오. * RF-flanged ends는 옵션으로 사용 가능합니다.

10K Gate Valve

10SMBOF
B.B.O.S.Y.
FF-flanged

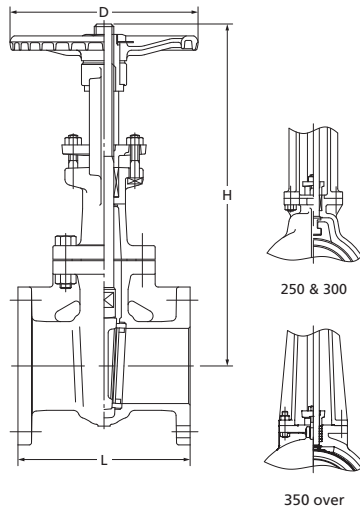
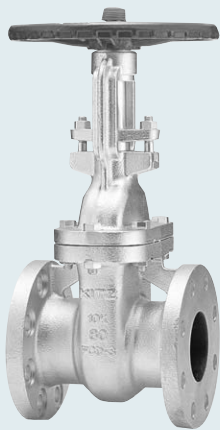

Face to face : JIS B 2002
End connection : JIS B 2239 10K

120°C Static water..... 1.4MPa
220°C Steam, air, gas, oil..... 1.2MPa
300°C Steam, air, gas, oil..... 1.0MPa

●윤활 또는 유압 오일에 사용할 수 있습니다. 밸브가 열 전달 매체로 사용되는 경우 KITZ Corporation에 기술적 조언을 문의하십시오.
●볼트재질은 225°C를 초과하는 고온용 서비스를 위해 변경이 가능합니다. 자세한 정보는 KITZ Corporation으로 문의하여 주십시오.

Materials

Parts	JIS material
Body	FCD-5
Bonnet	FCD-5
Stem	403SS
Disc	403SS / SCS1 (40~200) A105 + 13Cr (250) SCPH2 + 13Cr (300~500)
Body seat ring	403SS
Gland	FCD-5 (400 & 500:403SS)
Gland packing	Non-asbestos Packing (50~300) Flexible Graphite Braided Packing (350~500)
Handwheel	Ductile Iron
Bonnet bolt/nut	Carbon Steel
Gland bolt/nut	Carbon Steel
Yoke sleeve	High Tension Brass(40~150) Cast Brass(200~300) Cast Bronze(350 & 450) Ductile Ni-resist(400 & 500)
Yoke	Ductile Iron
Gasket	Stainless Foil Inserted Flexible Graphite
Name plate	Aluminum

NOTE : Reduced port (450&500)

Dimensions

Size	mm															
	mm	40	50	65	80	100	125	150	200	250	300	350	400	450	500	
	inch	1 1/2	2	2 1/2	3	4	5	6	8	10	12	14	16	18	20	
L		165	178	190	203	229	254	267	292	330	356	381	406	432	457	
H (open)		300	352	410	479	566	667	779	969	1181	1404	1358	1702	1538	1702	
D		160	200	200	250	250	300	300	350	400	450	500	600	500	600	

NOTE : Flange의 크기는 44페이지를 참조하십시오. * RF-flanged ends는 옵션으로 사용 가능합니다.

JIS 10K Lift Check Valve

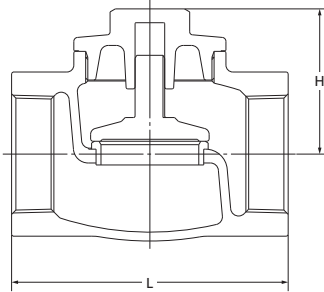

End to end : JIS B 2051
End connection : JIS B 0203

120°C Static water..... 1.4MPa
220°C Steam, air, gas, oil..... 1.0MPa

●윤활 또는 유압 오일에 사용할 수 있습니다. 밸브가 열 전달 매체로 사용되는 경우 KITZ Corporation에 기술적 조건을 문의하십시오.

Materials

Parts	JIS material
Body	FCD-S
Cap	SCS1
Disc	SCS1
Body seat ring	403SS

Dimensions

Size	mm						
	mm	15	20	25	32	40	50
	inch	1/2	3/4	1	1 1/4	1 1/2	2
L		65	80	90	105	120	140
H		39	42	48	56	65	73

10K Lift Check Valve

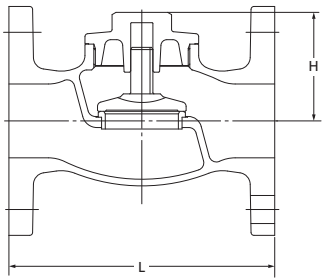

Face to face : JIS B 2011
End connection : JIS B 2239 10K

120°C Static water..... 1.4MPa
220°C Steam, air, gas, oil..... 1.0MPa

●윤활 또는 유압 오일에 사용할 수 있습니다. 밸브가 열 전달 매체로 사용되는 경우 KITZ Corporation에 기술적 조건을 문의하십시오.

Materials

Parts	JIS material
Body	FCD-S
Cap	SCS1
Disc	SCS1
Body seat ring	403SS

Dimensions

Size	mm						
	mm	15	20	25	32	40	50
	inch	1/2	3/4	1	1 1/4	1 1/2	2
L		85	95	110	130	150	180
H		39	42	48	56	65	73

NOTE : Flange의 크기는 44페이지를 참조하십시오. *RF-flanged ends는 옵션으로 사용 가능합니다.

10K Lift Check Valve

10SN
S.C.

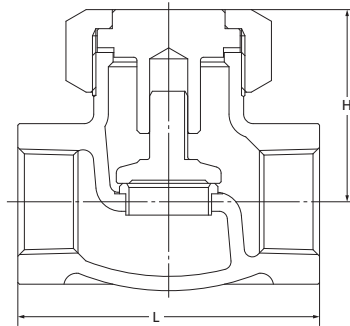

End to end : JV 4-4
End connection : JIS B 0203

120°C Static water..... 1.4MPa
220°C Steam, air, gas, oil..... 1.2MPa

●유탈 또는 유압 오일에 사용할 수 있습니다. 밸브가 열 전달 매체로 사용되는 경우 KITZ Corporation에 기술적 조안을 문의하십시오.

Materials

Parts	JIS material
Body	FCD-5
Bonnet	304SS
Disc	SCS1
Body seat ring	403SS
Gasket	Tough Pitch Copper

Dimensions

Size	mm						
	mm	15	20	25	32	40	50
	inch	1/2	3/4	1	1 1/4	1 1/2	2
L		70	80	90	110	120	140
H		50	53	61	69	75	87

10K Swing Check Valve

10SOZ

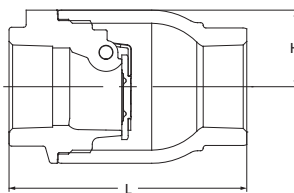
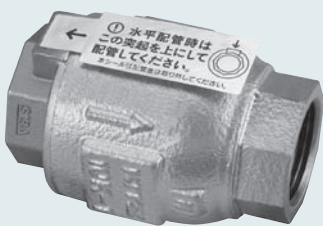

Face to face : JIS B2051
End connection : JIS B0203

120°C Static water..... 1.4MPa
220°C Steam, air, gas, oil..... 1.0MPa

●유탈 또는 유압 오일에 사용할 수 있습니다. 밸브가 열 전달 매체로 사용되는 경우 KITZ Corporation에 기술적 조안을 문의하십시오.

Materials

Parts	JIS material
Body	FCD-5
Cap	SCS13A / A351Gr.CF8
Disc	304SS
Hinge pin	304SS
Arm	304SS

Dimensions

Size	mm						
	mm	15	20	25	32	40	50
	inch	1/2	3/4	1	1 1/4	1 1/2	2
L		65	80	90	105	120	140
H		21.5	24.5	29	35	41.5	48.5

10K Lift Check Valve

10SNBF
U.B.
FF-flanged

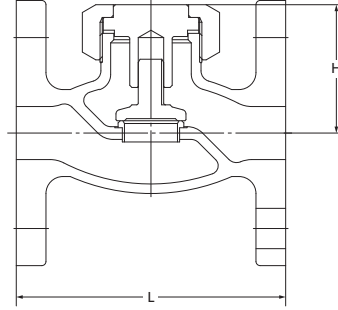
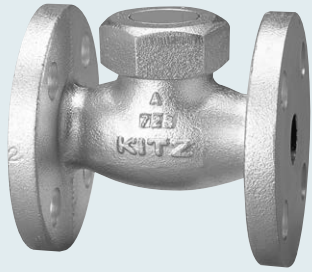

Face to face : JIS B 2002 JV 4-4
End connection : JIS B 2239 10K

120°C Static water..... 1.4MPa
220°C Steam, air, gas, oil..... 1.2MPa

- 윤활 또는 유압 오일에 사용할 수 있습니다. 밸브가 열 전달 매체로 사용되는 경우 KITZ Corporation에 기술적 조언을 문의하십시오.
- 볼트 재질은 225°C를 넘는 고온용으로 교체됩니다. 자세한 내용은 KITZ Corporation으로 문의하시기 바랍니다.

Materials

Parts	JIS material
Body	FCD-5
Bonnet	304SS
Disc	SCS1
Bonnet ring	FCD-5
Gasket	Tough Pitch Copper
Body seat ring	403SS

Dimensions

Size	mm						
	mm	15	20	25	32	40	50
	inch	1/2	3/4	1	1 1/4	1 1/2	2
L		108	117	127	140	165	203
H		50	53	61	69	75	87

NOTE : Flange의 크기는 44페이지를 참조하십시오. ※RF-flanged ends는 옵션으로 사용 가능합니다.

10K Swing Check Valve

10SRBF
B.C.
FF-flanged

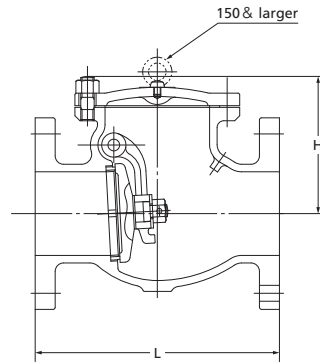

Face to face : JIS B 2002
End connection : JIS B 2239 10K

120°C Static water..... 1.4MPa
220°C Steam, air, gas, oil..... 1.2MPa
300°C Steam, air, gas, oil..... 1.0MPa

- 윤활 또는 유압 오일에 사용할 수 있습니다. 밸브가 열 전달 매체로 사용되는 경우 KITZ Corporation에 기술적 조언을 문의하십시오.
- 볼트재질은 225°C를 초과하는 고온용 서비스를 위해 변경이 가능합니다. 자세한 정보는 KITZ Corporation으로 문의하여 주십시오.
- Gasket은 260°C의 고온에 밸브를 적용하기 위해 Plug를 Sealing하는데 사용됩니다. 사전에 서비스 온도를 명시해 주십시오. 밸브의 보수를 위해 Plug Gasket을 교체해야하는것을 유념하십시오.

Materials

Parts	JIS material
Body	FCD-5
Cover	FCD-5
Disc	403SS(200 ~ 300 : SCPH2 + 13Cr)
Disc nut	SS400 (125 ~ 300 : 304SS)
Body seat ring	403SS
Arm	SCS13A (125 ~ 300 : SCHP2)
Hinge pin	403SS
Split pin	304SS
Plug	SS400 (125 ~ 300 : S45C)
Washer	SS400 (125 ~ 300 : 403SS)
Gasket	Non-asbestos Sheet
Cover bolt/nut	Carbon Steel

Dimensions

Size	mm										
	mm	40	50	65	80	100	125	150	200	250	300
	inch	1 1/2	2	2 1/2	3	4	5	6	8	10	12
L		165	203	216	241	292	330	356	495	622	698
H		115	120	130	145	160	195	215	255	310	350

NOTE : Flange의 크기는 44페이지를 참조하십시오. ※RF-flanged ends는 옵션으로 사용 가능합니다.

10K Strainer for Gas Service

10FDY
B.C. or S.C.

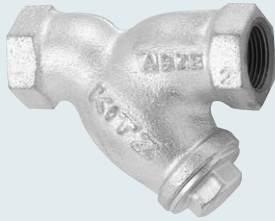

B.C. for 2 1/2" & 3"
S.C. for 2" & smaller

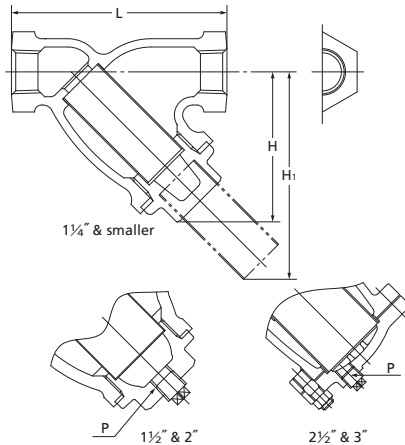

End to end : KITZ Std.
End connection : JIS B 0203

120°C Static water..... 1.4MPa
200°C Steam, air, gas, oil..... 1.0MPa

- 윤활 또는 유압 오일에 사용할 수 있습니다. 밸브가 열 전달 매체로 사용되는 경우 KITZ Corporation에 기술적 조언을 문의하십시오.
- Copper Cap을 사용하면 Ammonia 또는 Amine 화합물질을 다루는데 이 밸브를 사용할 수 없습니다.

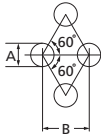

Screen Hole Size		
Valve Size	A	B
1/4" ~ 2"	1.4	2.4
2 1/2" & 3"	1.5	2.5

Materials

Parts	JIS material
Body	FCD-S
Cap (1/4" ~ 2")	C3771
Cover (2 1/2" & 3")	FCD-S
Gasket	Non-asbestos (2 1/2" & 3" : Flexible Graphite)
Screen	304SS
Plug *	304SS

* 1 1/2" & larger

Dimensions

Size	mm	8	10	15	20	25	32	40	50	65	80
	inch	1/4	3/8	1/2	3/4	1	1 1/4	1 1/2	2	2 1/2	3
L		65	70	85	100	115	135	150	180	220	250
H		46	46	60	65	75	90	100	115	191	215
P		—	—	—	—	—	Rc 3/8	Rc 1/2	Rc 1/4	Rc 1/4	Rc 1/4
H1		63	63	85	95	110	130	145	170	271	311

10K Strainer for Gas Service

10FDYBF
B.C. or S.C.
FF-flanged

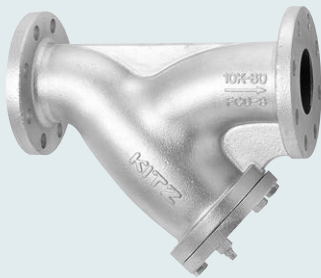

B.C. for 50 & larger
S.C. for 40 & smaller

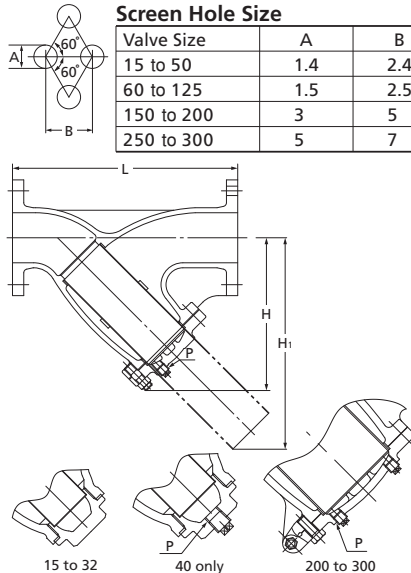

Face to face : KITZ Std.
End connection : JIS B 2239 10K

Screen Hole Size

Valve Size	A	B
15 to 50	1.4	2.4
60 to 125	1.5	2.5
150 to 200	3	5
250 to 300	5	7

120°C Static water..... 1.4MPa
220°C Steam, air, gas, oil..... 1.2MPa
300°C Steam, air, gas, oil..... 1.0MPa
Size 15^A ~ 40^A: 1.2MPa

- 윤활 또는 유압 오일에 사용할 수 있습니다. 밸브가 열 전달 매체로 사용되는 경우 KITZ Corporation에 기술적 조언을 문의하십시오.
- Copper Cap을 사용하면 Ammonia 또는 Amine 화합물질을 다루는데 이 밸브를 사용할 수 없습니다.
- 볼트재질은 225°C를 초과하는 고온용 서비스를 위해 변경이 가능합니다. 자세한 정보는 KITZ Corporation으로 문의하여 주십시오.
- Gasket은 260°C의 고온에 밸브를 적용하기 위해 Plug를 Sealing하는데 사용됩니다. 사전에 서비스 온도를 명시해 주십시오. 밸브의 보수를 위해 Plug Gasket을 교체해야하는것을 유념하십시오.

Materials

Parts	JIS material
Body	FCD-S
Cap(15~40)	C3771
Cover(50~300)	FCD-S
Gasket	Non-asbestos (50 ~ 300:Flexible Graphite)
Screen	304SS
Cover bolt/nut	Carbon Steel
Plug *	304SS

* 40 & larger

Dimensions

Size	mm	15	20	25	32	40	50	65	80	100	125	150	200	250	300
	inch	1/2	3/4	1	1 1/4	1 1/2	2	2 1/2	3	4	5	6	8	10	12
L		125	140	150	170	190	230	305	360	415	465	515	580	680	800
H		57	63	77	90	100	138	212	242	284	325	370	462	536	625
P		—	—	—	—	Rc 3/8	Rc 1/4	Rc 1/4	Rc 1/4	Rc 3/4	Rc 3/4	Rc 3/4	Rc 3/4	Rc 3/4	Rc 3/4
H1		82	91	114	134	146	172	290	340	391	450	502	645	757	882

NOTE : Flange의 크기는 44페이지를 참조하십시오. * RF-flanged ends는 옵션으로 사용 가능합니다.

16K Globe Valve

16SP
U.B.I.S.

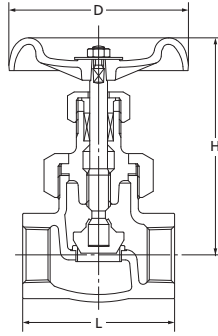
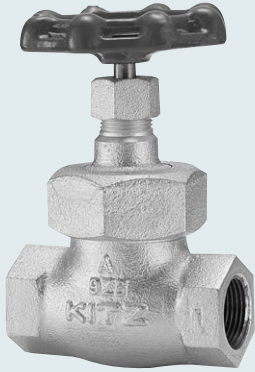

End to end : KITZ Std.
End connection : JIS B 0203

120°C Static water..... 2.2MPa
220°C Steam, air, gas, oil..... 2.0MPa

- 윤활 또는 유압 오일에 사용할 수 있습니다. 밸브가 열 전달 매체로 사용되는 경우 KITZ Corporation에 기술적 조언을 문의하십시오.
- Copper Cap을 사용하면 Ammonia 또는 Amine화합물질을 다루는데 해당 밸브를 사용할 수 없습니다.

Materials

Parts	JIS material
Body	FCD-S
Bonnet	FCD-S
Stem	SUS420J2
Disc	403SS
Gland	SUS420J2(1 1/4": 403SS)
Gland packing	Non-asbestos Packing
Body seat ring	403SS
Handwheel	Ductile Iron
Bonnet ring	FCD-S
Gasket	Tough Pitch Copper

Dimensions

Size	mm							
	mm	10	15	20	25	32	40	50
	inch	3/8	1/2	3/4	1	1 1/4	1 1/2	2
L		64	70	85	95	110	125	145
H (open)		110	122	128	147	165	182	196
D		60	80	80	100	115	115	135

16K Globe Valve

16SPB
U.B.I.S.
RF-flanged

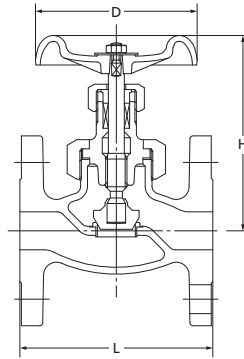

Face to face : JIS B 2002 JV 4-4 *
End connection : JIS B 2239 16K
* KITZ Std. for 10

120°C Static water..... 2.2MPa
220°C Steam, air, gas, oil..... 2.0MPa

- 윤활 또는 유압 오일에 사용할 수 있습니다. 밸브가 열 전달 매체로 사용되는 경우 KITZ Corporation에 기술적 조언을 문의하십시오.
- Copper Cap을 사용하면 Ammonia 또는 Amine화합물질을 다루는데 해당 밸브를 사용할 수 없습니다.

Materials

Parts	JIS material
Body	FCD-S
Bonnet	FCD-S
Stem	SUS420J2
Disc	403SS
Gland	SUS420J2(32 : 403SS)
Gland packing	Non-asbestos Packing
Body seat ring	403SS
Handwheel	Ductile Iron
Bonnet ring	FCD-S
Gasket	Tough Pitch Copper

Dimensions

Size	mm							
	mm	10	15	20	25	32	40	50
	inch	3/8	1/2	3/4	1	1 1/4	1 1/2	2
L		108	108	117	127	140	165	203
H (open)		111	122	128	146	165	182	198
D		60	80	80	100	115	115	135

NOTE : Flange의 크기는 44페이지를 참조하십시오.

16K Globe Valve

16SPBO
B.B.O.S.Y.
RF-flanged

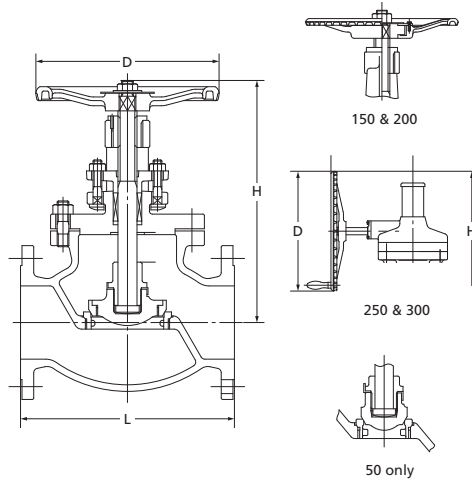

Face to face : JIS B 2002 *
End connection : JIS B 2239 16K
*KITZ Std. for 125 & 150.

120°C Static water..... 2.2MPa
220°C Steam, air, gas, oil..... 2.0MPa
300°C Steam, air, gas, oil..... 1.8MPa
350°C Steam, air, gas, oil..... 1.6MPa

●윤활 또는 유압 오일에 사용할 수 있습니다. 밸브가 열 전달 매체로 사용되는 경우 KITZ Corporation에 기술적 조건을 문의하십시오.

Materials

Parts	JIS material
Body	FCD-5
Bonnet	FCD-5
Stem	403SS
Disc	FCD-5 (50 : 403SS)
Gland	FCD-5
Gland packing	Non-asbestos Packing
Handwheel *	Ductile Iron
Gasket	Non-asbestos Sheet
Body seat ring	403SS
Disc seat ring	403SS
Yoke bush *	High Tension Brass
Bonnet bolt/nut	Carbon Steel
Name plate	Aluminum

* 200 & smaller

Dimensions

Size	mm	50	65	80	100	125	150	200	250	300	mm
	inch	2	2½	3	4	5	6	8	10	12	
L		203	216	241	292	356	406	495	622	698	
H (open)		302	313	356	377	460	524	585	880	943	
D		200	225	250	250	300	350	400	360	360	

NOTE : Flange의 크기는 44페이지를 참조하십시오.

16K Gate Valve

16SMS
U.B.I.S.

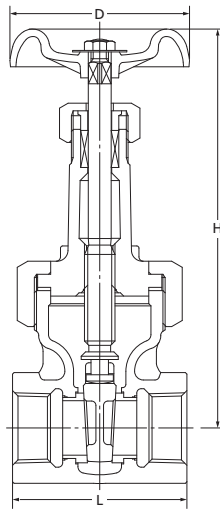
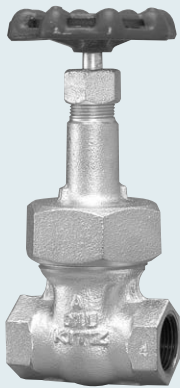

End to end : JV 4-2
End connection : JIS B 0203

120°C Static water..... 2.2MPa
220°C Steam, air, gas, oil..... 2.0MPa

●윤활 또는 유압 오일에 사용할 수 있습니다. 밸브가 열 전달 매체로 사용되는 경우 KITZ Corporation에 기술적 조건을 문의하십시오.
●Copper Cap를 사용하면 Ammonia 또는 Amine화합물질을 다루는데 해당 밸브를 사용할 수 없습니다.

Materials

Parts	JIS material
Body	FCD-5
Bonnet	FCD-5
Stem	SUS420J2
Disc	SCS1
Gland	SUS420J2(1¼" : 403SS)
Gland packing	Non-asbestos Packing
Bonnet ring	FCD-5
Body seat ring	403SS
Gasket	Tough Pitch Copper
Handwheel	Ductile Iron
Name plate	Aluminum

Dimensions

Size	mm	15	20	25	32	40	50	mm
	inch	½	¾	1	1¼	1½	2	
L		65	75	80	90	100	110	
H (open)		163	182	212	245	285	330	
D		70	80	90	100	115	135	

16K Gate Valve

16SMB
U.B.I.S.
RF-flanged

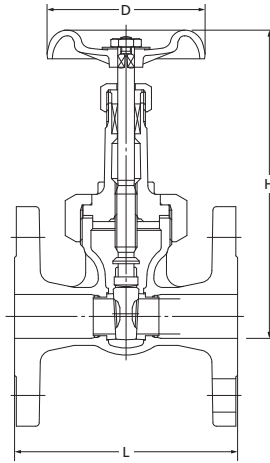

Face to face : JIS B2002 JV 4-2
End connection : JIS B2239 16K

120°C Static water..... 2.2MPa
220°C Steam, air, gas, oil..... 2.0MPa

- 윤활 또는 유압 오일에 사용할 수 있습니다. 밸브가 열 전달 매체로 사용되는 경우 KITZ Corporation에 기술적 조언을 문의하십시오.
- Copper Cap을 사용하면 Ammonia 또는 Amine화합물질을 다루는데 해당 밸브를 사용할 수 없습니다.

Materials

Parts	JIS material
Body	FCD-S
Bonnet	FCD-S
Stem	SUS420J2
Disc	SCS1
Gland	SUS420J2 (40 : 403SS)
Gland packing	Non-asbestos Packing
Handwheel	Ductile Iron
Bonnet ring	FCD-S
Gasket	Tough Pitch Copper
Body seat ring	403SS
Name plate	Aluminum

Dimensions

Size	mm						
	mm	15	20	25	32	40	50
	inch	1/2	3/4	1	1 1/4	1 1/2	2
L		108	117	127	140	165	178
H (open)		163	164	187	219	253	285
D		70	70	80	90	100	115

NOTE : Flange의 크기는 44페이지를 참조하십시오.

16K Gate Valve

16SMBO
B.B.O.S.Y.
RF-flanged

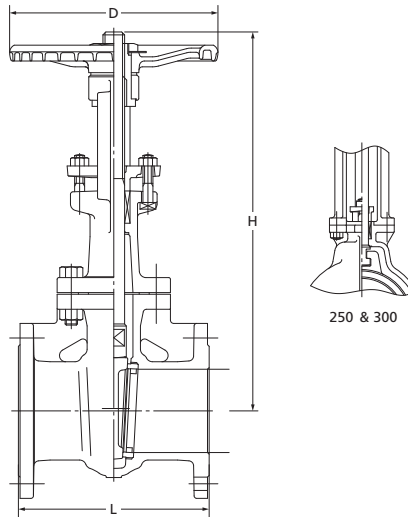
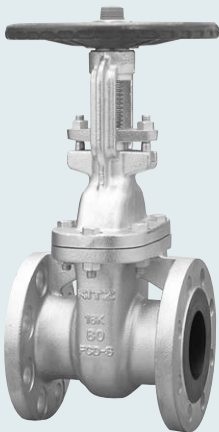

Face to face : JIS B 2002
End connection : JIS B 2239 16K

120°C Static water..... 2.2MPa
220°C Steam, air, gas, oil..... 2.0MPa
300°C Steam, air, gas, oil..... 1.8MPa
350°C Steam, air, gas, oil..... 1.6MPa

- 윤활 또는 유압 오일에 사용할 수 있습니다. 밸브가 열 전달 매체로 사용되는 경우 KITZ Corporation에 기술적 조언을 문의하십시오.

Materials

Parts	JIS material
Body / Bonnet	FCD-S
Stem	403SS
Disc	403SS / SCS1 (40 ~ 200) A105+13Cr (250) SCPH2+13Cr (300)
Gland	FCD-S
Gland packing	Non-asbestos Packing
Handwheel	Ductile Iron
Gasket	Non-asbestos Sheet
Body seat ring	403SS
Bonnet bolt/nut	Carbon Steel
Gland bolt/nut	Carbon Steel
Yoke sleeve	High Tension Brass (200 ~ 300 : Cast Brass)
Yoke	Ductile Iron
Name plate	Aluminum

Dimensions

Size	mm										
	mm	40	50	65	80	100	125	150	200	250	300
	inch	1 1/2	2	2 1/2	3	4	5	6	8	10	12
L		165	178	190	203	229	254	267	292	330	356
H (open)		300	352	410	479	566	667	779	969	1181	1404
D		160	200	200	250	250	300	300	350	400	450

NOTE : Flange의 크기는 44페이지를 참조하십시오.

16K Lift Check Valve

16SF
U.B.

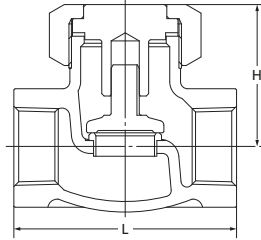

Face to face : KITZ Std.
End connection : JIS B 0203

120°C Static water..... 2.2MPa
220°C Steam, air, gas, oil..... 2.0MPa

- 윤활 또는 유압 오일에 사용할 수 있습니다. 밸브가 열 전달 매체로 사용되는 경우 KITZ Corporation에 기술적 조언을 문의하십시오.
- Copper Cap을 사용하면 Ammonia 또는 Amine화합물질을 다루는데 해당 밸브를 사용할 수 없습니다.

Materials

Parts	JIS material
Body	FCD-5
Bonnet	SCS13A
Disc	SCS1
Bonnet ring	FCD-5
Gasket	Tough Pitch Copper
Body seat ring	403SS

Dimensions

Size	mm						
	mm	15	20	25	32	40	50
	inch	1/2	3/4	1	1 1/4	1 1/2	2
L		70	85	95	110	125	145
H		50	53	61	69	75	87

16K Lift Check Valve

16SFB
U.B.

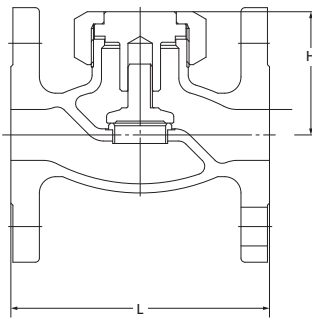
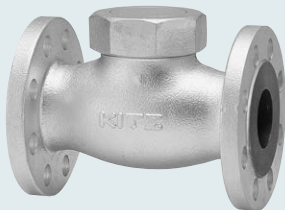

Face to face : JIS B 2002 JV 4-2
End connection : JIS B 2239 16K

120°C Static water..... 2.2MPa
220°C Steam, air, gas, oil..... 2.0MPa

- 윤활 또는 유압 오일에 사용할 수 있습니다. 밸브가 열 전달 매체로 사용되는 경우 KITZ Corporation에 기술적 조언을 문의하십시오.
- Copper Cap을 사용하면 Ammonia 또는 Amine화합물질을 다루는데 해당 밸브를 사용할 수 없습니다.

Materials

Parts	JIS material
Body	FCD-5
Bonnet	SCS13A
Disc	SCS1
Bonnet ring	FCD-5
Gasket	Tough Pitch Copper
Body seat ring	403SS

Dimensions

Size	mm						
	mm	15	20	25	32	40	50
	inch	1/2	3/4	1	1 1/4	1 1/2	2
L		108	117	127	140	165	203
H		50	53	61	69	75	87

NOTE : Flange의 크기는 44페이지를 참조하십시오.

16K Swing Check Valve

16SRB

B.C.
RF-flanged

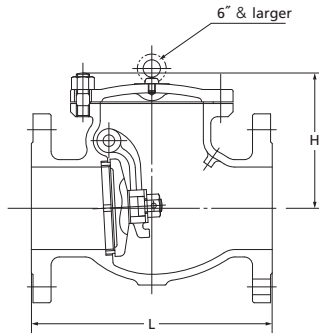

Face to face : JIS B 2002
End connection : JIS B 2239 16K

120°C Static water..... 2.2MPa
220°C Steam, air, gas, oil..... 2.0MPa
300°C Steam, air, gas, oil..... 1.8MPa
350°C Steam, air, gas, oil..... 1.6MPa

- 윤활 또는 유압 오일에 사용할 수 있습니다. 밸브가 열 전달 매체로 사용되는 경우 KITZ Corporation에 기술적 조언을 문의하십시오.
- Gasket은 260°C의 고온에 밸브를 적용하기 위해 Plug를 Sealing하는데 사용됩니다. 사전에 서비스 온도를 명시해 주십시오. 밸브의 보수를 위해 Plug Gasket을 교체해야하는것을 유념하십시오.

Materials

Parts	JIS material
Body	FCD-5
Cover	FCD-5
Disc	403SS (200 ~ 300 : SCPH2 + 13Cr)
Body seat ring	403SS
Arm	SCS13A (125 ~ 300 : SCPH2)
Split pin	304SS
Hinge pin	403SS
Plug	SS400
Washer	SS400 (125 ~ 300 : 403SS)
Gasket	Non-asbestos Sheet
Cover bolt/nut	Carbon Steel

Dimensions

Size	mm	50	65	80	100	125	150	200	250	300	mm
	inch	2	2½	3	4	5	6	8	10	12	
L		203	216	241	292	330	356	495	622	698	
H		120	135	145	165	200	220	265	320	360	

NOTE : Flange의 크기는 44페이지를 참조하십시오.

16K Y-Pattern Strainer

16FDY

S.C.

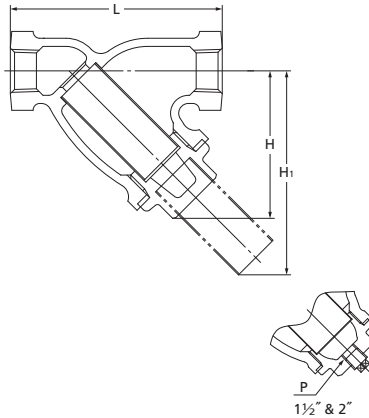
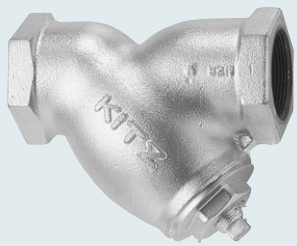

End to end : KITZ Std.
End connection : JIS B 0203

120°C Static water..... 2.2MPa
220°C Steam, air, gas, oil..... 2.0MPa

- 윤활 또는 유압 오일에 사용할 수 있습니다. 밸브가 열 전달 매체로 사용되는 경우 KITZ Corporation에 기술적 조언을 문의하십시오.
- Copper Cap를 사용하면 Ammonia 또는 Amine화학물질을 다루는데 해당 밸브를 사용할 수 없습니다.

Materials

Parts	JIS material
Body	FCD-5
Cap	C3771
Gasket	Non-asbestos Sheet
Screen	304SS
Plug*	304SS

* 1½" & larger

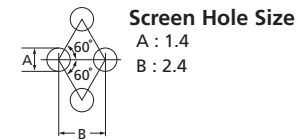

Dimensions

Size	mm	15	20	25	32	40	50	mm
	inch	½	¾	1	1¼	1½	2	
L		85	100	115	135	150	180	
H		60	65	75	90	100	115	
P		—	—	—	—	Rc ³ / ₈	Rc ¹ / ₂	
H1		85	95	110	130	145	170	

16K Y-Pattern Strainer

16FDYB
B.C. or S. C.
RF-flanged

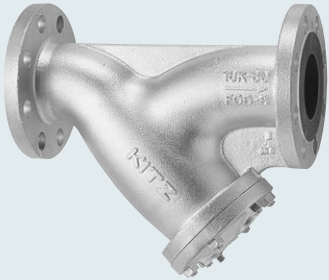

B.C. for 50 & larger
S.C. for 40 & smaller

Face to face : KITZ Std.
End connection : JIS B 2239 16K

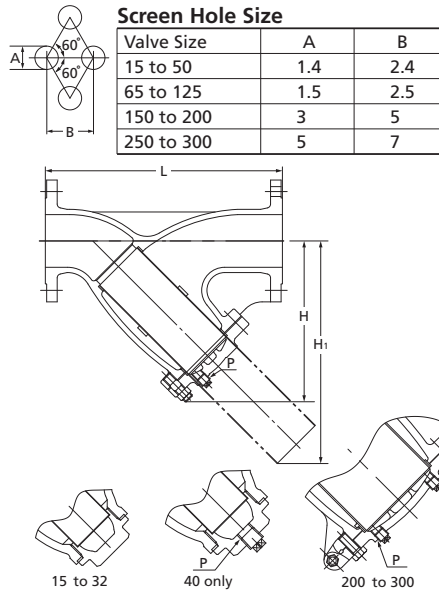

120°C Static water..... 2.2MPa
220°C Steam, air, gas, oil..... 2.0MPa
300°C Steam, air, gas, oil..... 1.8MPa
350°C Steam, air, gas, oil..... 1.6MPa
15 ~ 40 : 260°C 1.9MPa

- 윤활 또는 유압 오일에 사용할 수 있습니다. 밸브가 열 전달 매체로 사용되는 경우 KITZ Corporation에 기술적 조언을 문의하십시오.
- Copper Cap을 사용하면 Ammonia 또는 Amine화합물질을 다루는데 해당 밸브를 사용할 수 없습니다.
- Gasket은 260°C의 고온에 밸브를 적용하기 위해 Plug를 Sealing하는데 사용됩니다. 사전에 서비스 온도를 명시해 주십시오. 밸브의 보수를 위해 Plug Gasket을 교체해야하는것을 유념하십시오.

Materials

Parts	JIS material
Body	FCD-5
Cap (15 ~ 40)	C3771
Cover (50 ~ 300)	FCD-5
Gasket	Non-asbestos (50~300 : Flexible Graphite)
Screen	304SS
Cover bolt	Carbon Steel
Plug *	304SS

* 2개의 Drain Plug는 크기가 200 및 그 이상의 밸브에 제공됩니다.

Dimensions

Size	mm	15	20	25	32	40	50	65	80	100	125	150	200	250	300
	inch	1/2	3/4	1	1 1/4	1 1/2	2	2 1/2	3	4	5	6	8	10	12
L		125	140	150	170	190	250	305	360	415	465	515	580	680	800
H		57	63	77	90	100	158	212	242	284	325	370	462	536	625
P		—	—	—	—	Rc ³ / ₈	Rc ¹ / ₄	Rc ¹ / ₄	Rc ¹ / ₄	Rc ³ / ₄	Rc ³ / ₄	Rc ³ / ₄	Rc ³ / ₄	Rc ³ / ₄	Rc ³ / ₄
H1		82	91	114	134	146	218	285	340	391	450	502	645	757	882

NOTE : Flange의 크기는 44페이지를 참조하십시오.

20K Globe Valve

20SY
U.B.I.S.

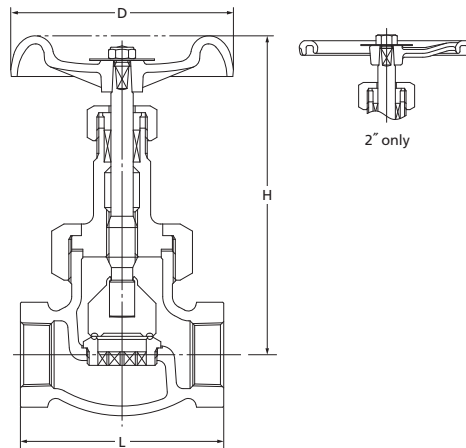
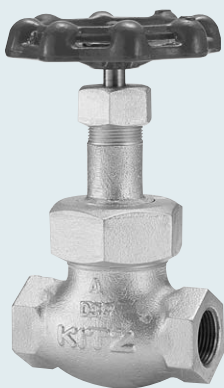

End to end : KITZ Std.
End connection : JIS B 0203

120°C Static water..... 2.8MPa
220°C Steam, air, gas, oil..... 2.5MPa
300°C Steam, air, gas, oil..... 2.3MPa
350°C Steam, air, gas, oil..... 2.0MPa

- 윤활 또는 유압 오일에 사용할 수 있습니다. 밸브가 열 전달 매체로 사용되는 경우 KITZ Corporation에 기술적 조언을 문의하십시오.
- Copper Cap을 사용하면 Ammonia 또는 Amine화합물질을 다루는데 해당 밸브를 사용할 수 없습니다.

Materials

Parts	JIS material
Body	FCD-5
Bonnet	FCD-5
Stem	SUS420J2
Disc	403SS + HF *
Body seat ring	SCS13A + HF *
Gland	SUS420J2 (1" & 2" : 403SS)
Gland packing	Non-asbestos Packing
Packing nut	FCD-5
Handwheel	Ductile Iron
Wheel nut	Carbon Steel
Bonnet ring	FCD-5
Gasket	Tough Pitch Copper
Name plate	Aluminum

* Hard-faced with Co-Cr-W alloy

Dimensions

Size	mm	10	15	20	25	32	40	50
	inch	3/8	1/2	3/4	1	1 1/4	1 1/2	2
L		75	78	91	105	122	135	160
H (open)		136	138	157	178	202	210	239
D		70	80	100	115	135	135	180

20K Globe Valve

20SYB
U.B.I.S.
RF-flanged

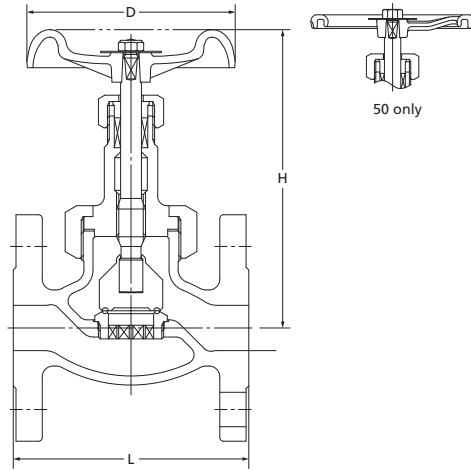

Face to face : JIS B 2002 JV 4-4*
End connection : JIS B 2239 20K
*KITZ Std. for 10

120°C Static water..... 2.8MPa
220°C Steam, air, gas, oil..... 2.5MPa
300°C Steam, air, gas, oil..... 2.3MPa
350°C Steam, air, gas, oil..... 2.0MPa

- 윤활 또는 유압 오일에 사용할 수 있습니다. 밸브가 열 전달 매체로 사용되는 경우 KITZ Corporation에 기술적 조언을 문의하십시오.
- Copper Cap을 사용하면 Ammonia 또는 Amine화합물질을 다루는 데 해당 밸브를 사용할 수 없습니다.

Materials

Parts	JIS material
Body	FCD-S
Bonnet	FCD-S
Stem	SUS420J2
Disc	403SS + HF*
Body seat ring	SCS13A + HF*
Gland	SUS420J2 (25 & 50 : 403SS)
Gland packing	Flexible Graphite Braided Packing
Packing nut	FCD-S
Handwheel	Ductile Iron
Wheel nut	Carbon Steel
Gasket	Tough Pitch Copper
Name plate	Aluminum

* Hard-faced with Co-Cr-W alloy

Dimensions

Size	mm							
	mm	10	15	20	25	32	40	50
	inch	3/8	1/2	3/4	1	1 1/4	1 1/2	2
L		110	110	120	130	160	180	230
H (open)		136	138	157	178	202	210	239
D		70	80	100	115	135	135	180

NOTE : Flange의 크기는 44페이지를 참조하십시오.

20K Globe Valve

20SYBO
B.B.O.S.Y.
RF-flanged

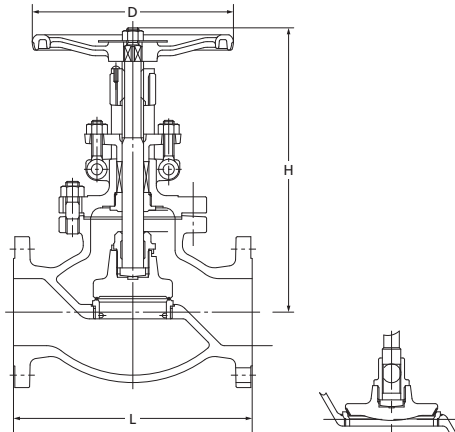

Face to face : JIS B 2002
End connection : JIS B 2239 20K

120°C Static water..... 2.8MPa
220°C Steam, air, gas, oil..... 2.5MPa
300°C Steam, air, gas, oil..... 2.3MPa
350°C Steam, air, gas, oil..... 2.0MPa

- 윤활 또는 유압 오일에 사용할 수 있습니다. 밸브가 열 전달 매체로 사용되는 경우 KITZ Corporation에 기술적 조언을 문의하십시오.

Materials

Parts	JIS material
Body	FCD-S
Bonnet	FCD-S
Stem	403SS
Disc	A105 + HF*
Lock nut	FCD-S (200 : 403SS)
Body seat ring	A105 + HF* (200 : 403SS + HF*)
Gland	FCD-S
Gland packing	Flexible Graphite Braided Packing
Handwheel	Ductile Iron
Wheel nut	Carbon Steel
Bonnet bolt/nut	Carbon Steel
Gland bolt/nut	Carbon Steel
Yoke bush	High Tension Brass
Gasket	Non-asbestos Sheet
Name plate	Aluminum

* Hard-faced with Co-Cr-W alloy

Dimensions

Size	mm							
	mm	50	65	80	100	125	150	200
	inch	2	2 1/2	3	4	5	6	8
L		267	292	318	356	400	444	559
H (open)		295	341	372	449	534	600	693
D		225	250	250	300	350	400	560

NOTE : Flange의 크기는 44페이지를 참조하십시오.

20K Globe Valve with Soft Disc for Gas Service

20SDL
U.B.I.S.



PTFE disc for gas service

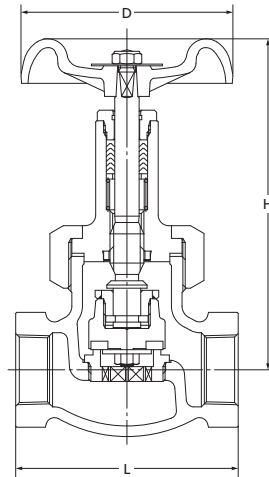

End to end : KITZ Std.
End connection : JIS B 0203

80°C gas..... 2.4MPa

Materials

Parts	JIS material
Body	FCD-5
Bonnet	FCD-5
Bonnet ring	FCD-5
Stem	SUS420J2
Disc	PTFE
Gland	SUS303
Gland packing	NBR
Handwheel	Aluminum Die-cast (3/8" & 1/2" : Zinc Die-Cast)
Gasket	Non-asbestos Sheet
Body seat ring	SCS13A
Stem washer	403SS

Dimensions

Size	mm							
	10	15	20	25	32	40	50	
	inch	3/8	1/2	3/4	1	1 1/4	1 1/2	2
L		75	78	91	105	122	135	160
H (open)		128	128	147	168	192	201	237
D		70	70	90	100	115	135	155

20K Globe Valve with Soft Disc for Gas Service

20SDLB
U.B.I.S.
RF-flanged.



PTFE disc for gas service

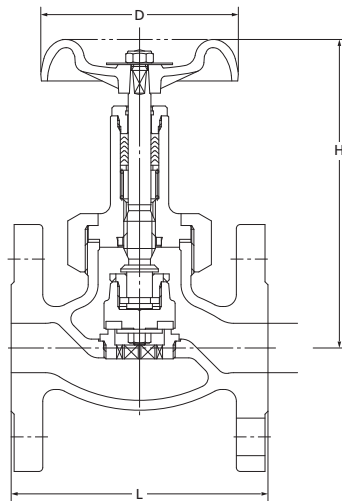

Face to face : JIS B 2002
End connection : JIS B 2239 20K

80°C gas..... 2.4MPa

Materials

Parts	JIS material
Body	FCD-5
Bonnet	FCD-5
Stem	SUS420J2
Disc	G/F PTFE
Gland	SUS303
Gland packing	NBR
Handwheel	Aluminum Die-cast (15 : Zinc Die-Cast)
Gasket	Non-asbestos Sheet
Body seat ring	SCS13A
Stem washer	403SS

Dimensions

Size	mm						
	15	20	25	32	40	50	
	inch	1/2	3/4	1	1 1/4	1 1/2	2
L		110	120	130	160	180	230
H (open)		128	147	168	192	201	237
D		70	90	100	115	135	155

NOTE : Flange의 크기는 44페이지를 참조하십시오.

20K Globe Valve with Soft Disc for Gas Service

20SDLBO
B.B.O.S.Y.
RF-flanged



PTFE disc for gas service

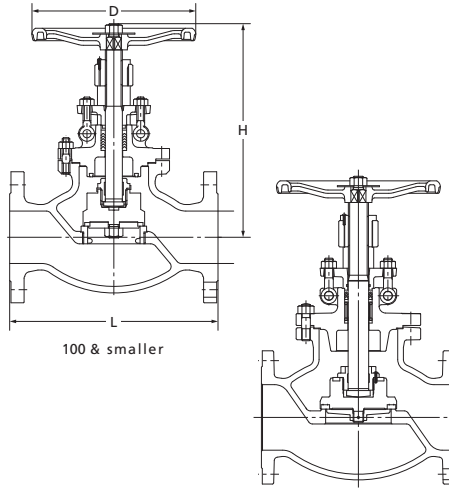

Face to face : JIS B 2002
End connection : JIS B 2239 20K

80°C gas..... 2.4MPa

Materials

Parts	JIS material
Body	FCD-S
Bonnet	FCD-S
Stem	403SS
Disc	PTFE
Gland	FCD-S
Gland packing	NBR + PTFE
Gasket	Non-asbestos Sheet
Body seat ring *	403SS
Stem washer *	SKD1
Disc washer *	403SS
Spring (150 & 200)	Stainless Steel
Bonnet bolt/nut	Carbon Steel
Handwheel	Ductile Iron

* 100 & smaller

Dimensions

Size	mm					
	mm	80	100	150	200	
	inch	2½	3	4	6	8
L		292	318	356	444	559
H (open)		337	351	439	600	688
D		250	250	300	400	560

NOTE : Flange의 크기는 44페이지를 참조하십시오.

20K Bellows Seal Globe Valve

20SYBOW
B.B.O.S.Y.
RF-flanged

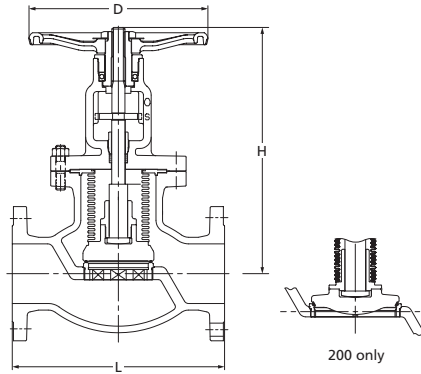

Face to face : JIS B2002
End connection : JIS B2239 20K

120°C Static water2.8MPa
350°C Steam, air, gas, oil.....2.0MPa

● 윤활 또는 유압 오일에 사용할 수 있습니다. 밸브가 열 전달 매체로 사용되는 경우 KITZ Corporation에 기술적 조건을 문의하십시오.

Materials

Parts	JIS material
Body	FCD-S
Bonnet	FCD-S
Stem	403SS
Disc	304SS+HF *
Gland	403SS
Gland packing	Flexible Graphite
Handwheel	Ductile Iron
Bonnet bolt/nut	Carbon Steel
Bellows	316LSS
Bellows holder	304SS
Body seat ring	SCS13A + HF *(15 ~ 50) 304SS + HF *(65 ~ 150) 403SS + HF *(200)
Name plate	Aluminum

* Hard-faced with Co-Cr-W alloy

Dimensions

Size	mm												
	mm	20	25	32	40	50	65	80	100	125	150	200	
	inch	¾	1	1¼	1½	2	2½	3	4	5	6	8	
L		110	120	130	160	180	230	292	318	356	400	444	559
H		184	184	190	238	238	271	285	395	432	529	586	749
D		90	90	100	140	140	160	180	250	300	350	400	450

NOTE : Flange의 크기는 44페이지를 참조하십시오.

20K Bellows Seal Globe Valve

20SDBOW

B.B.O.S.Y
RF-flanged



Reinforced PTFE disc

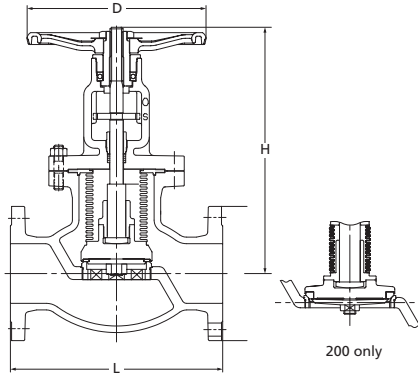

Face to face : JIS B2002
End connection : JIS B2239 20K

120°C Static water2.5MPa
180°C Steam, air, gas, oil.....2.0MPa

●윤활 또는 유압 오일에 사용할 수 있습니다. 밸브가 열 전달 매체로 사용되는 경우 KITZ Corporation에 기술적 조언을 문의하십시오.

Materials

Parts	JIS material
Body	FCD-S
Bonnet	FCD-S
Stem	403SS
Disc	G/F PTFE
Gland	403SS
Gland packing	Flexible Graphite
Handwheel	Ductile Iron
Bonnet bolt/nut	Carbon Steel
Bellows	316LSS
Bellows holder	304SS
Body seat ring	304SS / SCS13A (200 : 403SS)
Name plate	Aluminum

Dimensions

Size	mm												
	15	20	25	32	40	50	65	80	100	125	150	200	
	inch	1/2	3/4	1	1 1/4	1 1/2	2	2 1/2	3	4	5	6	8
L		110	120	130	160	180	230	292	318	356	400	444	559
H		184	184	190	238	238	271	285	395	432	529	586	749
D		90	90	100	140	140	160	180	250	300	350	400	450

NOTE : Flange의 크기는 44페이지를 참조하십시오.

20K Gate Valve

20SLS

B.B.I.S.

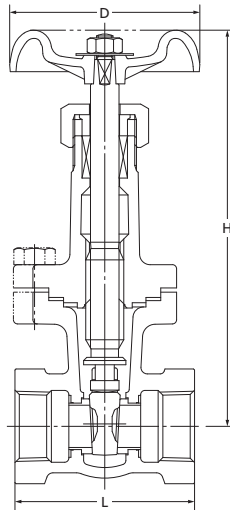
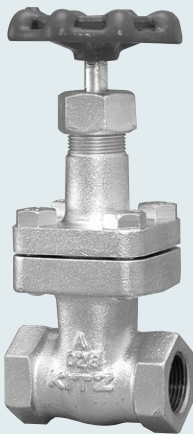

End to end : JV 4-4
End connection : JIS B 0203

120°C Static water..... 2.8MPa
220°C Steam, air, gas, oil..... 2.5MPa
300°C Steam, air, gas, oil..... 2.3MPa
350°C Steam, air, gas, oil..... 2.0MPa

●윤활 또는 유압 오일에 사용할 수 있습니다.

Materials

Parts	JIS material
Body	FCD-S
Bonnet	FCD-S
Stem	SUS420J2
Disc	SCS1
Gland	SUS420J2 (1 1/2" & 2" : 403SS)
Gland packing	Non-asbestos Packing
Handwheel	Ductile Iron
Gasket	Non-asbestos Sheet
Body seat ring	403SS
Name plate	Aluminum

Dimensions

Size	mm						
	15	20	25	32	40	50	
	inch	1/2	3/4	1	1 1/4	1 1/2	
L		70	75	85	95	105	115
H (open)		175	177	214	241	277	301
D		90	90	100	115	135	135

20K Gate Valve

20SLB
B.B.I.S.
RF-flanged

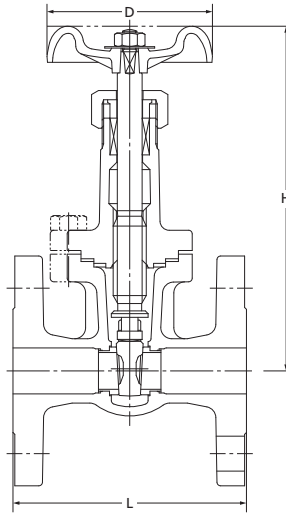

Face to face : JIS B 2002 JV 4-4
End connection : JIS B 2239 20K

120°C Static water..... 2.8MPa
220°C Steam, air, gas, oil..... 2.5MPa
300°C Steam, air, gas, oil..... 2.3MPa
350°C Steam, air, gas, oil..... 2.0MPa

●윤활 또는 유압 오일에 사용할 수 있습니다.

Materials

Parts	JIS material
Body	FCD-S
Bonnet	FCD-S
Stem	SUS420J2
Disc	SCS1
Body seat ring	403SS
Gland	SUS420J2 (40 : 403SS)
Gland packing	Non-asbestos Packing
Handwheel	Ductile Iron
Wheel nut	Carbon Steel
Bonnet bolt	Carbon Steel
Gasket	Non-asbestos Sheet
Name plate	Aluminum

Dimensions

Size	mm					
	mm	15	20	25	32	40
	inch	1/2	3/4	1	1 1/4	1 1/2
L		108	117	127	140	165
H (open)		175	177	214	241	277
D		90	90	100	115	135

NOTE : Flange의 크기는 44페이지를 참조하십시오.

20K Gate Valve

20SLBO
B.B.O.S.Y.
RF-flanged

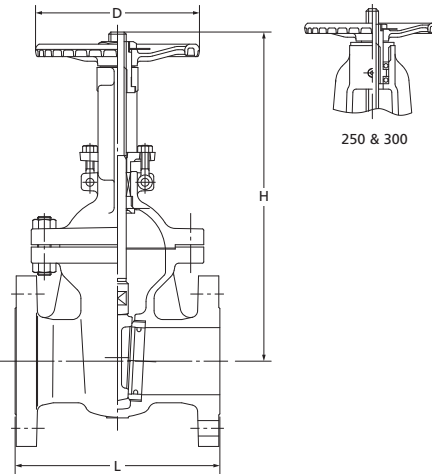
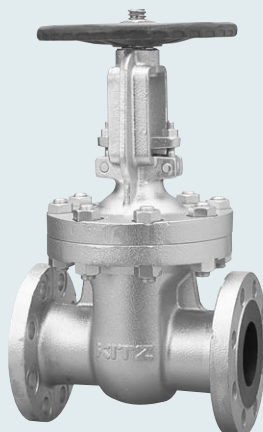

Face to face : JIS B 2002
End connection : JIS B 2239 20K

120°C Static water..... 2.8MPa
220°C Steam, air, gas, oil..... 2.5MPa
300°C Steam, air, gas, oil..... 2.3MPa
350°C Steam, air, gas, oil..... 2.0MPa

●윤활 또는 유압 오일에 사용할 수 있습니다.

Materials

Parts	JIS material
Body	FCD-S
Bonnet	FCD-S
Stem	403SS
Disc	403SS (50~150) SCPH2+13cr (200~300) SCS1 (400only)
Body seat ring	403SS
Gland	FCD-S
Gland packing	Non-asbestos Packing
Handwheel	Ductile Iron
Wheel nut	Carbon Steel
Bonnet bolt/nut	Carbon Steel
Gland bolt/nut	Carbon Steel
Yoke sleeve	High Tension Brass (150~200 : Cast Brass)
Gasket	Non-asbestos Sheet
Name plate	Aluminum

Dimensions

Size	mm										
	mm	40	50	65	80	100	125	150	200	250	300
	inch	1 1/2	2	2 1/2	3	4	5	6	8	10	12
L		190	216	241	283	305	381	403	419	457	502
H (open)		326	395	450	520	595	725	820	1070	1247	1451
D		160	200	200	250	250	300	350	400	450	500

NOTE : Flange의 크기는 44페이지를 참조하십시오.

20K Lift Check Valve

20SN
U.B.

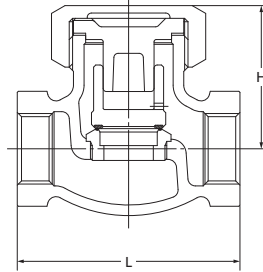

End to end : KITZ Std.
End connection : JIS B 0203

120°C Static water..... 2.8MPa
220°C Steam, air, gas, oil..... 2.5MPa
300°C Steam, air, gas, oil..... 2.3MPa
350°C Steam, air, gas, oil..... 2.0MPa

● 윤활 또는 유압 오일에 사용할 수 있습니다.

Materials

Parts	JIS material
Body	FCD-5
Bonnet	SCS1
Disc	SCS13A + HF *
Bonnet ring	FCD-5
Gasket	Non-asbestos Sheet
Body seat ring	SCS13A + HF *

* Hard-faced with Co-Cr-W alloy

Dimensions

Size	mm						
	mm	15	20	25	32	40	50
	inch	1/2	3/4	1	1 1/4	1 1/2	2
L		78	91	105	122	135	160
H		56	60	68	80	85	99

20K Lift Check Valve

20SNB
U.B.
RF-flanged

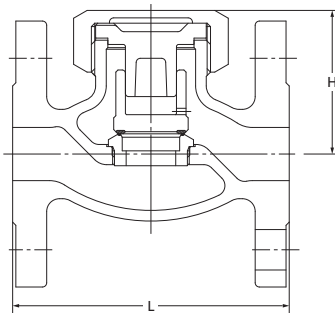
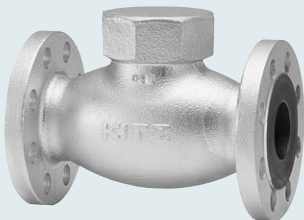

Face to face : JIS B 2002 JV 4-4
End connection : JIS B 2239 20K

120°C Static water..... 2.8MPa
220°C Steam, air, gas, oil..... 2.5MPa
300°C Steam, air, gas, oil..... 2.3MPa
350°C Steam, air, gas, oil..... 2.0MPa

● 윤활 또는 유압 오일에 사용할 수 있습니다.

Materials

Parts	JIS material
Body	FCD-5
Bonnet	SCS1
Disc	SCS13A + HF *
Bonnet ring	FCD-5
Gasket	Non-asbestos Sheet
Body seat ring	SCS13A + HF *

* Hard-faced with Co-Cr-W alloy

Dimensions

Size	mm						
	mm	15	20	25	32	40	50
	inch	1/2	3/4	1	1 1/4	1 1/2	2
L		110	120	130	160	180	230
H		56	60	68	80	85	99

NOTE : Flange의 크기는 44페이지를 참조하십시오.

20K Lift Check Valve for Gas Service

20SNDB

U.B.
RF-flanged



PTFE disc for gas service

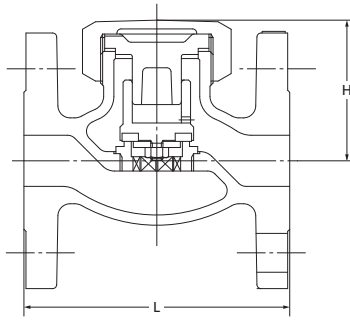

Face to face : JIS B 2002 JV 4-4
End connection : JIS B 2239 20K

120°C gas..... 2.4MPa

Materials

Parts	JIS material
Body	FCD-S
Bonnet	SCS1
Bonnet ring	FCD-S
Disc	PTFE
Disc holder	304SS
Gasket	Non-asbestos Sheet
Body seat ring	SCS13A
Disc washer	304SS

Dimensions

Size	mm						
	mm	15	20	25	32	40	50
	inch	1/2	3/4	1	1 1/4	1 1/2	2
L		110	120	130	160	180	230
H		56	60	68	80	85	99

NOTE : Flange의 크기는 44페이지를 참조하십시오.

20K Swing Check Valve

20SOB

B.C.
RF-flanged

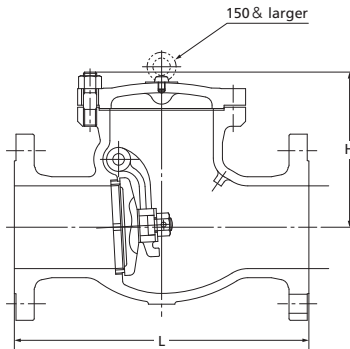
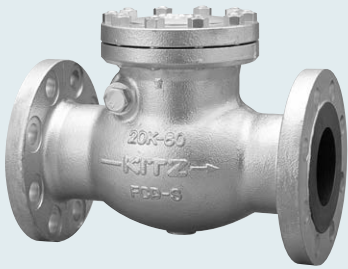

Face to face : JIS B 2002
End connection : JIS B 2239 20K

120°C Static water..... 2.8MPa
220°C Steam, air, gas, oil..... 2.5MPa
300°C Steam, air, gas, oil..... 2.3MPa
350°C Steam, air, gas, oil..... 2.0MPa

Materials

Parts	JIS material
Body	FCD-S
Cover	FCD-S
Disc	403SS (200~300:SCPH2 + 13Cr)
Disc nut	SS400 (125 ~300: 304SS)
Body seat ring	403SS
Arm	SCS13A (125 ~300: SCPH2)
Hinge pin	403SS
Split pin	304SS
Plug	SS400
Washer	SS400 (125 ~300: 403SS)
Gasket	Non-asbestos Sheet
Cover bolt/nut	Carbon Steel

Dimensions

Size	mm									
	mm	50	65	80	100	125	150	200	250	300
	inch	2	2 1/2	3	4	5	6	8	10	12
L		267	292	318	356	400	444	533	622	711
H		135	145	160	185	220	240	275	335	370

NOTE : Flange의 크기는 44페이지를 참조하십시오.

20K Swing Check Valve for Gas Service

20SODB
B.C. or U.B.
RF-flanged

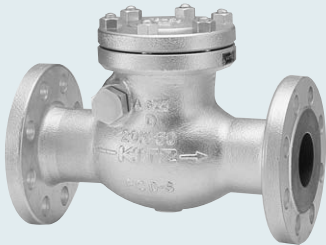

PTFE disc for gas service
B.C. for 40 & larger
U.B. for 25 only

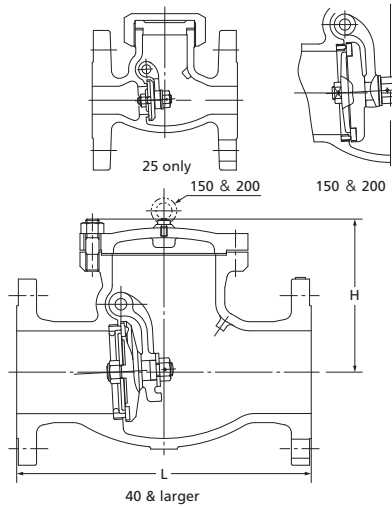

Face to face : JIS B 2002
End connection : JIS B 2239 20K

120°C gas..... 2.4MPa

Materials

Parts	JIS material
Body	FCD-S
Cap (25 only)	S25C
Cover (40 ~ 200)	FCD-S
Disc	PTFE
Disc holder	403SS
Gasket	Non-asbestos Sheet
Body seat ring	403SS
Arm	SCS13A (25: FCD-S / 150&200:SCPH2)
Hinge pin	403SS
Split pin	304SS
Cover bolt/nut	Carbon Steel
Bushing	403SS

Dimensions

Size	mm								
	mm	25	40	50	65	80	100	150	200
	inch	1	1½	2	2½	3	4	6	8
L		130	241	267	292	318	356	444	533
H		78	123	135	145	160	185	240	280

NOTE : Flange의 크기는 44페이지를 참조하십시오.

20K Strainer for Gas Service

20FDY
B.C.

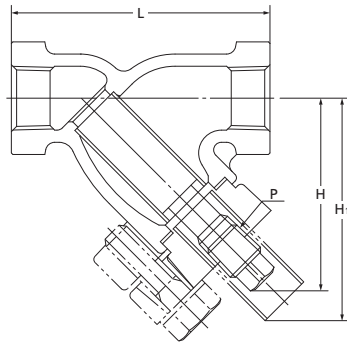

End to end : KITZ Std.
End connection : JIS B 0203

120°C Static water..... 2.8MPa
220°C Steam, air, gas, oil..... 2.5MPa
300°C Steam, air, gas, oil..... 2.3MPa
350°C Steam, air, gas, oil..... 2.0MPa

- 윤활 또는 유압 오일에 사용할 수 있습니다.
- Gasket은 260°C의 고온에 밸브를 적용하기 위해 Plug를 Sealing 하는데 사용됩니다. 사전에 서비스 온도를 명시해 주십시오. 밸브의 보수를 위해 Plug Gasket을 교체해야하는것을 유념하십시오.

Materials

Parts	JIS material
Body	FCD-S
Cover	FCD-S
Gasket	Flexible Graphite
Screen *	304SS
Plug	304SS
Cover bolt	Carbon Steel

* 40 mesh wire cloth (reinforced with SUS304 punched plate)

Dimensions

Size	mm							
	mm	10	15	20	25	32	40	50
	inch	3/8	1/2	3/4	1	1¼	1½	2
L		80	85	100	115	135	150	180
H		65	65	70	83	120	130	152
P		Rc1/4	Rc1/4	Rc3/8	Rc1/2	Rc3/4	Rc1	Rc1¼
H1		74	74	85	102	122	134	161

20K Strainer for Gas Service

20FDYB
B.C.
RF-flanged

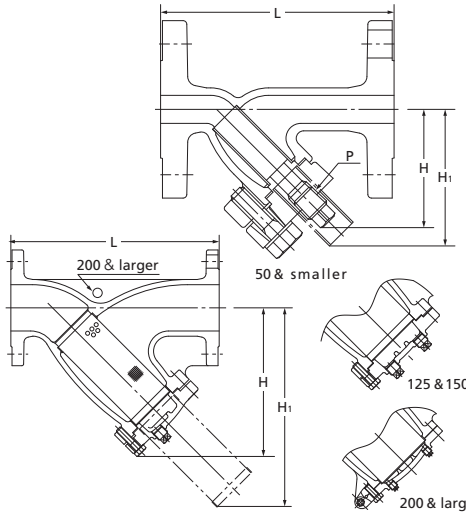
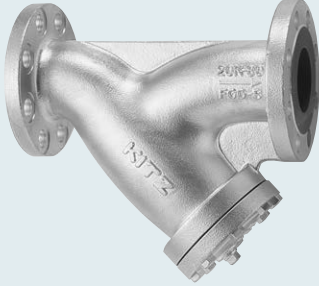

Face to face : KITZ Std.
End connection : JIS B 2239 20K

120°C Static water..... 2.8MPa
220°C Steam, air, gas, oil..... 2.5MPa
300°C Steam, air, gas, oil..... 2.3MPa
350°C Steam, air, gas, oil..... 2.0MPa

- 윤활 또는 유압 오일에 사용할 수 있습니다.
- Gasket은 260°C의 고온에 밸브를 적용하기 위해 Plug를 Sealing 하는데 사용됩니다. 사전에 서비스 온도를 명시해 주십시오. 밸브의 보수를 위해 Plug Gasket을 교체해야하는것을 유념하십시오.

Materials

Parts	JIS material
Body	FCD-S
Cover	FCD-S
Gasket	Flexible Graphite
Screen *	304SS
Plug	304SS
Cover bolt	Carbon Steel

* 40 mesh wire cloth (reinforced with SUS304 punched plate)

Dimensions

Size	mm	10	15	20	25	32	40	50	65	80	100	125	150	200	250	300
	inch	3/8	1/2	3/4	1	1 1/4	1 1/2	2	2 1/2	3	4	5	6	8	10	12
L		120	125	140	160	185	200	250	305	360	415	465	515	620	760	870
H		65	65	70	85	124	135	163	222	254	294	335	382	442	548	654
P		Rc1/4	Rc1/4	Rc3/8	Rc1/2	Rc3/4	Rc1	Rc1 1/4	Rc1/2	Rc1/2	Rc3/4	Rc3/4	Rc3/4	Rc1	Rc1	Rc1
H1		74	74	85	105	126	139	172	299	345	398	457	508	570	733	895

NOTE : Flange의 크기는 44페이지를 참조하십시오.

Class 150 Globe Valve

150SPB
U.B.I.S.
RF-flanged

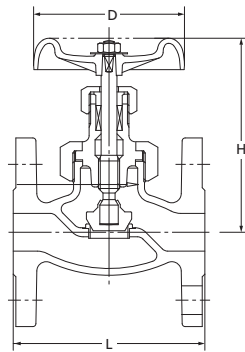

Face to face : ASME B16.10
End connection : ASME B16.5

-5°C ~ +38°C W.O.G. 1.73MPa
149°C W.O.G. 1.48MPa
260°C W.O.G. 1.18MPa
343°C W.O.G. 0.86MPa

- 윤활 또는 유압 오일에 사용할 수 있습니다.
- Copper Cap을 사용하면 Ammonia 또는 Amine화학물질을 다루는데 이 밸브를 사용할 수 없습니다.

Materials

Parts	JIS material
Body	FCD-S
Bonnet	FCD-S
Stem	SUS420J2
Disc	403SS
Gland	SUS420J2 (1 1/4" : 403SS)
Gland packing	Non-asbestos Packing
Handwheel	Ductile Iron
Gasket	Tough Pitch Copper
Body seat ring	403SS

Dimensions

Size	mm	15	20	25	32	40	50
	inch	1/2	3/4	1	1 1/4	1 1/2	2
L		108	117	127	140	165	203
H (open)		122	128	146	165	179	198
D		80	80	100	115	115	135

NOTE : Flange의 크기는 45페이지를 참조하십시오.

Class 150 Globe Valve

150SPBO
B.B.O.S.Y.
RF-flanged

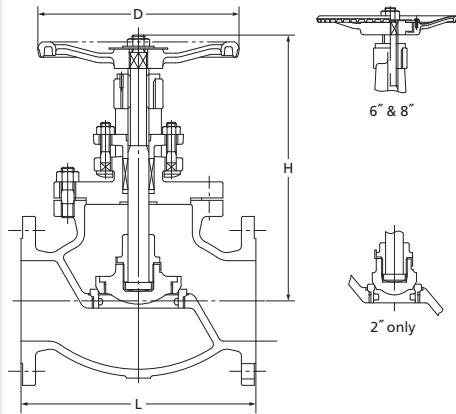

-5°C ~ +38°C W.O.G. 1.73MPa
149°C W.O.G. 1.48MPa
260°C W.O.G. 1.18MPa
343°C W.O.G. 0.86MPa

● 윤활 또는 유압 오일에 사용할 수 있습니다.

Materials

Parts	JIS material
Body	FCD-S
Bonnet	FCD-S
Stem	403SS
Disc	FCD-S (2" : 403SS)
Gland	FCD-S
Gland packing	Non-asbestos Packing
Handwheel	Ductile Iron
Gasket	Non-asbestos Sheet
Body seat ring	403SS
Disc seat ring	403SS
Yoke bush	High Tension Brass

Face to face : ASME B16.10
End connection : ASME B16.5

Dimensions

Size	mm	50	65	80	100	125	150	200
	inch	2	2½	3	4	5	6	8
L		203	216	241	292	356	406	495
H (open)		302	317	356	377	460	524	585
D		200	225	250	250	300	350	400

NOTE : Flange의 크기는 45페이지를 참조하십시오.

Class 150 Globe Valve

150SPDB
U.B.I.S.
RF-flanged



Reinforced PTFE disc

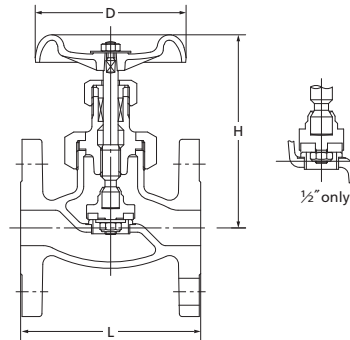

-5°C ~ +38°C W.O.G. 1.73MPa
149°C W.O.G. 1.48MPa
180°C W.O.G. 1.18MPa

● 윤활 또는 유압 오일에 사용할 수 있습니다.
● Copper Cap을 사용하면 Ammonia 또는 Amine화합물질을 다루는데 해당 밸브를 사용할 수 없습니다.

Materials

Parts	JIS material
Body	FCD-S
Bonnet	FCD-S
Stem	SUS420J2
Disc	G/F PTFE
Gland	SUS420J2 (1¼" : 403SS)
Gland packing	Non-asbestos Packing
Handwheel	Ductile Iron
Gasket	Tough Pitch Copper
Body seat ring	403SS

Face to face : ASME B16.10
End connection : ASME B16.5

Dimensions

Size	mm	15	20	25	32	40	50
	inch	½	¾	1	1¼	1½	2
L		108	117	127	140	165	203
H (open)		127	135	155	172	193	208
D		70	70	90	100	115	135

NOTE : Flange의 크기는 45페이지를 참조하십시오.

Class 150 Gate Valve

150SMBO
B.B.O.S.Y.
RF-flanged

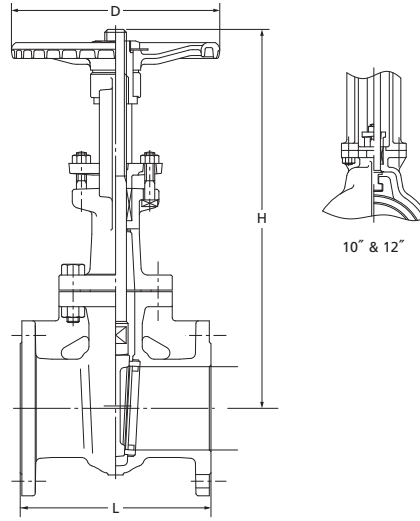
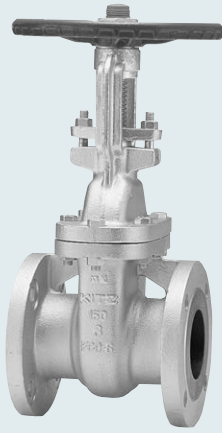

Face to face : ASME B16.10
End connection : ASME B16.5

-5°C ~ +38°C W.O.G. 1.73MPa
149°C W.O.G. 1.48MPa
260°C W.O.G. 1.18MPa
343°C W.O.G. 0.86MPa

● 윤활 또는 유압 오일에 사용할 수 있습니다.

Materials

Parts	JIS material
Body	FCD-5
Bonnet	FCD-5
Stem	4035S
Disc	4035S / SCS1 (1 1/2" ~ 8") A105 + 13Cr (10") SCPH2 + 13Cr (12")
Gland	FCD-5
Gland packing	Non-asbestos Packing
Handwheel	Ductile Iron
Gasket	Non-asbestos Sheet
Body seat ring	4035S
Yoke sleeve	High Tension Brass (8" ~ 12" : Cast Brass)
Yoke	Ductile Iron

Dimensions

Size	mm										
	mm	40	50	65	80	100	125	150	200	250	300
	inch	1 1/2	2	2 1/2	3	4	5	6	8	10	12
L		165	178	190	203	229	254	267	292	330	356
H (open)		300	352	408	473	566	667	779	969	1181	1404
D		160	200	200	250	250	300	300	350	400	450

NOTE : Flange의 크기는 45페이지를 참조하십시오.

Class 150 Swing Check Valve

150SRB
B.C.
RF-flanged

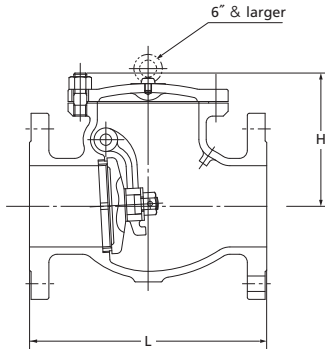

Face to face : ASME B16.10
End connection : ASME B16.5

-5°C ~ +38°C W.O.G. 1.73MPa
149°C W.O.G. 1.48MPa
260°C W.O.G. 1.18MPa
343°C W.O.G. 0.86MPa

● 윤활 또는 유압 오일에 사용할 수 있습니다.

● 볼트 재질은 225°C를 넘는 고온용으로 교체됩니다. 자세한 내용은 KITZ Corporation으로 문의하시기 바랍니다.

● Gasket은 260°C의 고온에 밸브를 적용하기 위해 Plug를 Sealing 하는데 사용됩니다. 사전에 서비스 온도를 명시해 주십시오. 밸브의 보수를 위해 Plug Gasket을 교체해야하는것을 유념하십시오.

Materials

Parts	JIS material
Body	FCD-5
Cover	FCD-5
Disc	4035S (8" ~ 12" : SCPH2 + 13Cr)
Disc nut	SS400 (5" ~ 12" : 304SS)
Split pin	304SS
Hinge pin	4035S
Plug	SS400
Gasket	Non-asbestos Sheet
Body seat ring	4035S
Arm	SCS13A (5" ~ 12" : SCPH2)
Cover bolt/nut	Carbon Steel

Dimensions

Size	mm										
	mm	40	50	65	80	100	125	150	200	250	300
	inch	1 1/2	2	2 1/2	3	4	5	6	8	10	12
L		165	203	216	241	292	330	356	495	622	698
H		115	120	130	145	165	200	220	260	320	360

NOTE : Flange의 크기는 45페이지를 참조하십시오.

Class 300 Globe Valve

300SYB
U.B.I.S.
RF-flanged

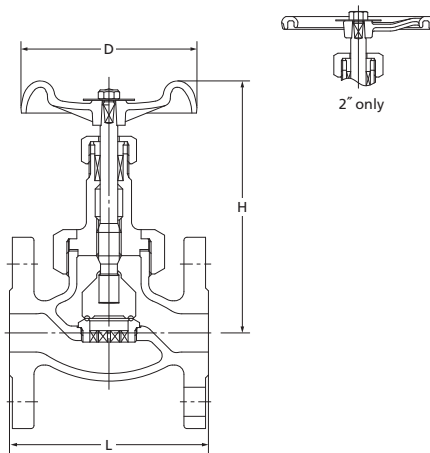

-5°C ~ +38°C W.O.G. 2.94MPa
149°C W.O.G. 2.60MPa
260°C W.O.G. 2.28MPa
350°C W.O.G. 2.04MPa

- 윤활 또는 유압 오일에 사용할 수 있습니다.
- Copper Cap을 사용하면 Ammonia 또는 Amine화합물질을 다루는데 해당 밸브를 사용할 수 없습니다.

Materials

Parts	JIS material
Body	FCD-5
Bonnet	FCD-5
Stem	SUS420J2
Disc	403SS + HF *
Gland	SUS420J2 (1" & 2": 403SS)
Gland packing	Flexible Graphite Braided Packing
Handwheel	Ductile Iron
Gasket	Tough Pitch Copper
Body seat ring	SCS13A + HF *

* Hard-faced with Co-Cr-W alloy

Face to face : JIS B 2002 JV 4-4
End connection : ASME B16.5

Dimensions

Size	mm					
	15	20	25	32	40	50
	1/2	3/4	1	1 1/4	1 1/2	2
L	110	120	130	160	180	230
H (open)	138	157	178	202	210	239
D	80	100	115	135	135	180

NOTE : Flange의 크기는 45페이지를 참조하십시오.

Class 300 Globe Valve

300SYBO
B.B.O.S.Y.
RF-flanged

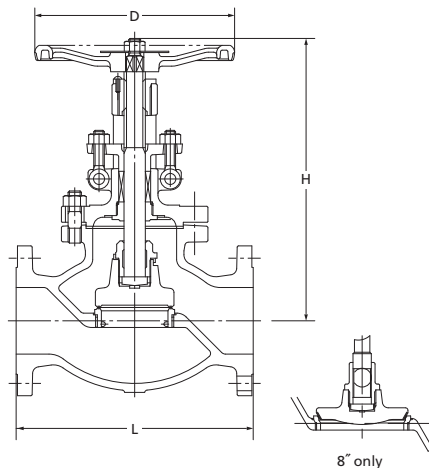
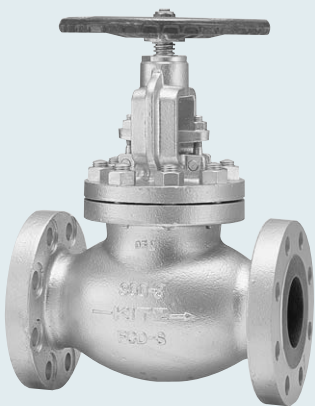

-5°C ~ +38°C W.O.G. 2.94MPa
149°C W.O.G. 2.60MPa
260°C W.O.G. 2.28MPa
350°C W.O.G. 2.04MPa

- 윤활 또는 유압 오일에 사용할 수 있습니다.

Materials

Parts	JIS material
Body	FCD-5
Bonnet	FCD-5
Stem	403SS
Disc	A105 + HF *
Gland	FCD-5
Gland packing	Flexible Graphite Braided Packing
Handwheel	Ductile Iron
Gasket	Non-asbestos Sheet
Body seat ring	A105 + HF *
Yoke bush	High Tension Brass

* Hard-faced with Co-Cr-W alloy

Face to face : ASME B16.10
End connection : ASME B16.5

Dimensions

Size	mm						
	50	65	80	100	125	150	200
	2	2 1/2	3	4	5	6	8
L	267	292	318	356	400	444	559
H (open)	243	347	382	457	534	593	697
D	225	250	250	300	350	400	560

NOTE : Flange의 크기는 45페이지를 참조하십시오.

Class 300 Gate Valve

300SLBO
B.B.O.S.Y.
RF-flanged

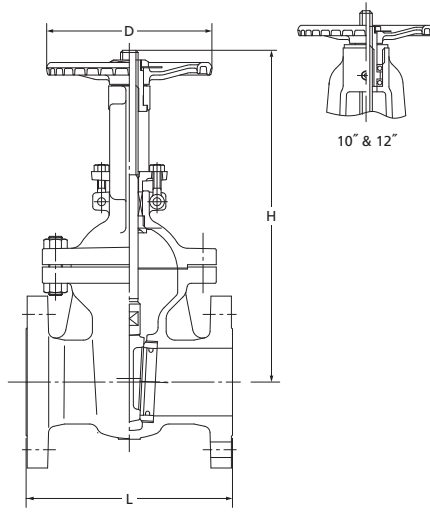

Face to face : ASME B16.10
End connection : ASME B16.5

-5°C ~ +38°C W.O.G. 2.94MPa
149°C W.O.G. 2.60MPa
260°C W.O.G. 2.28MPa
350°C W.O.G. 2.04MPa

●윤활 또는 유압 오일에 사용할 수 있습니다.

Materials

Parts	JIS material
Body	FCD-5
Bonnet	FCD-5
Stem	403SS
Disc	403SS (8" ~ 12" : SCPH2 + 13Cr)
Gland	FCD-5
Gland packing	Non-asbestos Packing
Handwheel	Ductile Iron
Body seat ring	403SS
Yoke sleeve	High Tension Brass (6" & 8" : Cast Brass)
Gasket	Non-asbestos Sheet
Bonnet bolt/nut	Carbon Steel

Dimensions

Size	mm	50	65	80	100	125	150	200	250	300
	inch	2	2½	3	4	5	6	8	10	12
L		216	241	283	305	381	403	419	457	502
H (open)		395	450	520	595	725	820	1070	1247	1451
D		200	200	250	250	300	350	400	450	500

NOTE : Flange의 크기는 45페이지를 참조하십시오.

Class 300 Swing Check Valve

300SOB
B.C.
RF-flanged

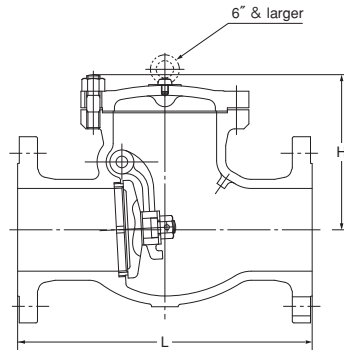
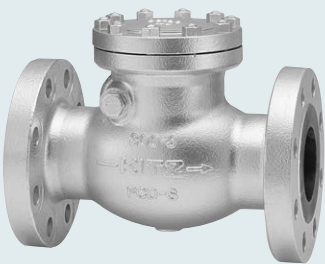

Face to face : ASME B16.10
End connection : ASME B16.5

-5°C ~ +38°C W.O.G. 2.94MPa
149°C W.O.G. 2.60MPa
260°C W.O.G. 2.28MPa
350°C W.O.G. 2.04MPa

●윤활 또는 유압 오일에 사용할 수 있습니다.

●Gasket은 260°C의 고온에 밸브를 적용하기 위해 Plug를 Sealing 하는데 사용됩니다. 사전에 서비스 온도를 명시해 주십시오. 밸브의 보수를 위해 Plug Gasket을 교체해야하는것을 유념하십시오.

Materials

Parts	JIS material
Body	FCD-5
Cover	FCD-5
Disc	403SS (8" ~ 12" : SCPH2 + 13Cr)
Disc nut	SS400 (5" ~ 12" : 304SS)
Split pin	304SS
Hinge pin	403SS
Plug	SS400
Gasket	Non-asbestos Sheet
Body seat ring	403SS
Arm	SCS13A (5" ~ 12" : SCPH2)
Cover bolt/nut	Carbon Steel

Dimensions

Size	mm	50	65	80	100	125	150	200	250	300
	inch	2	2½	3	4	5	6	8	10	12
L		267	292	318	356	400	444	533	622	711
H		135	145	160	185	220	240	275	335	370

NOTE : Flange의 크기는 45페이지를 참조하십시오.

10K Ball Valve Full Bore

10STBF
10STLBF (Gas service)
FF-flanged

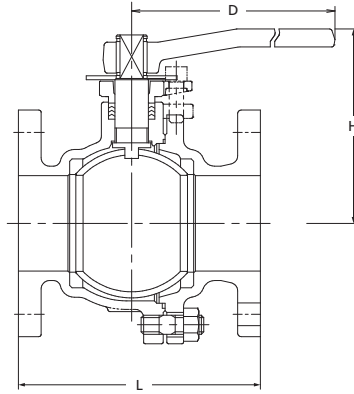

Face to face : ASME B16.10
End connection : JIS B 2239 10K

Maximum Service Pressure

Code	Valve size	Temperature	Pressure
10STBF	All size	120°C W.O.G.	1.4MPa
	4" and smaller	160°C W.O.G.	1.0MPa
	5" to 8"	140°C W.O.G.	1.0MPa
10STLBF	All size	80°C gas	1.2MPa

● 윤활 또는 유압 오일에 사용할 수 있습니다.

Materials

Parts	JIS material
Body	FCD-5
Body cap	FCD-5
Stem	403SS
Ball	304SS
Gland	FCD-5
Gland packing	PTFE
Handle	Ductile Iron
Gasket	PTFE
Packing washer	304SS (15 ~ 32)
Ball seat	HYPATITE PTFE *1 (10STBF) PTFE (10STLBF)
Cap bolt	S5400 *2
Cap nut	S5400 (10STBF), Carbon Steel (10STLBF)
Gland bolt	Alloy Steel
O ring *3	NBR
Stopper	Stainless Steel
Name plate *3	Stainless Steel

*1 PTFE 또는 C/F PTFE 는 옵션으로 사용가능 합니다.
*2 온도 범위가 0~225°C를 초과하는 경우 다른 볼트/너트 재질이 필요합니다. 기술적 자문은 KITZ Corporation에 문의하시길 바랍니다.
*3 10STLBF 에만 가능합니다.
밸브 액추에이터에 대한 내용은 KITZ로 문의하여 주시길 바랍니다.

Dimensions

Size	mm												
	mm	15	20	25	32	40	50	65	80	100	125	150	200
	inch	1/2	3/4	1	1 1/4	1 1/2	2	2 1/2	3	4	5	6	8
L		108	117	127	140	165	178	190	203	229	356	394	457
H		106	109	130	135	115	120	153	162	199	219	293	352
D		130	130	160	160	230	230	400	400	460	460	1000	1500

NOTE1 : Flange 크기의 경우 44페이지를 참고하십시오. ※ RF-flanged ends 선택적으로 사용이 가능합니다.
2 : Ball의 크기는 밸브의 크기에 따릅니다.

10K Ball Valve 3-way 4-seat

10STB4LAF (L port. Full Bore 40~100)
10STB4TAF (T port. Full Bore 40~100)
10STR4LAF (L port. Reduced Bore 125 & larger)
10STR4TAF (T port. Reduced Bore 125 & larger)

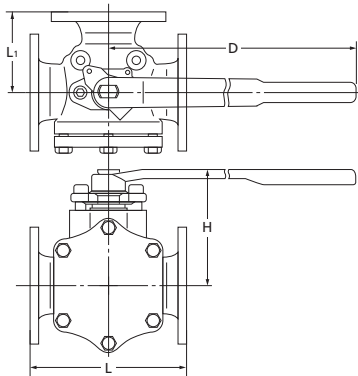

Face to face : KITZ Std.
End connection : JIS B 2239

120°C W.O.G. 1.0MPa
150°C W.O.G. 0.4MPa

Materials

Parts	JIS material
Body	FCD-5
Body cap	FCD-5
Ball	SCS13A / 304SS
Stem	304SS
Ball seat	HYPATITE PTFE
Gland packing	PTFE

Gear 작동은 크기 150과 200에만 옵션으로 사용됩니다.

Dimensions

Size	mm								
	mm	40	50	65	80	100	125	150	200
	inch	1 1/2	2	2 1/2	3	4	5	6	8
L	(STB)	180	200	240	260	330	—	—	—
	(STR)	—	—	—	—	—	340	400	450
L1	(STB)	90	100	120	130	165	—	—	—
	(STR)	—	—	—	—	—	170	200	225
H	(STB)	143	152	183	190	259	—	—	—
	(STR)	—	—	—	—	—	267	289	334
D	(STB)	400	400	460	460	1000	—	—	—
	(STR)	—	—	—	—	—	1000	1000	1500

NOTE : Flange 크기의 경우 44페이지를 참고하십시오. ※ RF-flanged ends 선택적으로 사용이 가능합니다.

20K Ball Valve Reduced Bore

20ST
20STL (Gas service)

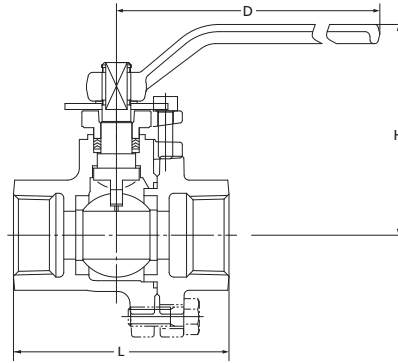

End to end : KITZ Std.
End connection : JIS B 0203

Maximum Service Pressure

Code	Temperature	Pressure
20ST	110°C W.O.G.	2.8MPa
	140°C W.O.G.	2.0MPa
20STL	80°C gas.	2.4MPa

● 윤활 또는 유압 오일에 사용할 수 있습니다.

Materials

Parts	JIS material
Body	FCD-S
Body cap	FCD-S
Stem	403SS
Ball	304SS
Gland	FCD-S
Gland packing	PTFE
Gasket	PTFE
Ball seat	HYPATITE PTFE
O ring *	NBR
Gland bolt	Alloy Steel
Cap bolt	Carbon Steel
Handle	Ductile Iron
Name plate *	Stainless Steel

* for 20STL only

Dimensions

Size	mm							
	mm	15	20	25	32	40	50	80**
	inch	1/2	3/4	1	1 1/4	1 1/2	2	3
L		75	80	90	105	115	130	180
H		106	106	107	129	133	114	154
D		130	130	130	160	160	230	400

** Custom order item (20STL only).

20K Ball Valve for Gas Service Full Bore

20STLB
RF-flanged

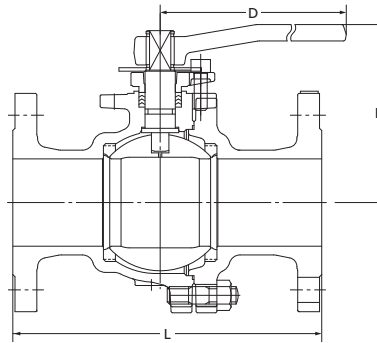
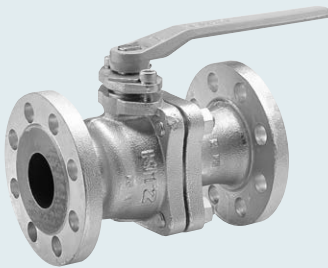

Face to face : ASME B16.10
End connection : JIS B 2239 20K

80°C Gas 2.4MPa

Materials

Parts	JIS material
Body	FCD-S
Body cap	FCD-S
Stem	403SS
Ball	304SS
Gland	FCD-S
Gland packing	PTFE
Gasket	PTFE
Ball seat	HYPATITE PTFE
O-ring	NBR
Cap bolt/nut	Carbon Steel
Stopper	Stainless Steel
Snap ring	Carbon Steel
Handle	Ductile Iron

Dimensions

Size	mm											
	mm	15	20	25	32	40	50	65	80	100	150	200
	inch	1/2	3/4	1	1 1/4	1 1/2	2	2 1/2	3	4	6	8
L		140	152	165	178	190	216	241	283	305	403	502
H (open)		106	109	130	135	115	120	153	162	241	293	352
D		130	130	160	160	230	230	400	400	750	1000	1500

NOTE1 : Flange 크기에 관한 정보는 44페이지를 참조하십시오.
2 : Ball의 크기는 밸브의 크기에 따라 달라집니다.

Class 400 Ball Valve Reduced Bore

STZ

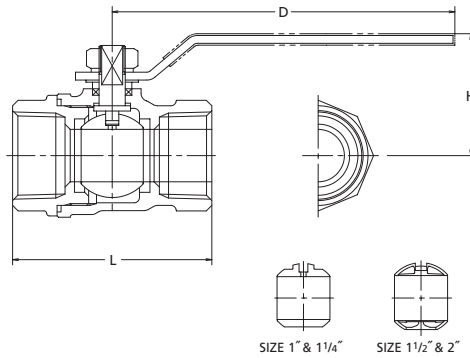

End to end : KITZ Std.
End connection : JIS B 0203

W.O.G. at Room temp 2.75MPa
Saturated steam 0.98MPa

● 윤활 또는 유압 오일에 사용할 수 있습니다.

Materials

Parts	JIS material
Body	FCD-S
Cap	FCD-S
Ball	C3771BE * ¹
Stem	Dezincification Resistant Brass * ¹
Gland packing	PTFE
Ball seat	G/F PTFE
Gland	C3604 * ²
Gasket	PTFE
Handle nut	Carbon Steel * ³
Handle	Stainless Steel * ⁴

*¹ Ni + Cr electroplated

*² Zinc electroplated

*³ Zinc dicromate electroplated

*⁴ Plastic covering

Dimensions

Size	mm								
	8	10	15	20	25	32	40	50	
	1/4	3/8	1/2	3/4	1	1 1/4	1 1/2	2	
L	46	51	57	65	76	86	95	115	
H	38	38	42	49	52	57	63	68	
D	80	80	100	130	130	130	130	150	

10K Wafer Check Valve

10SWZU

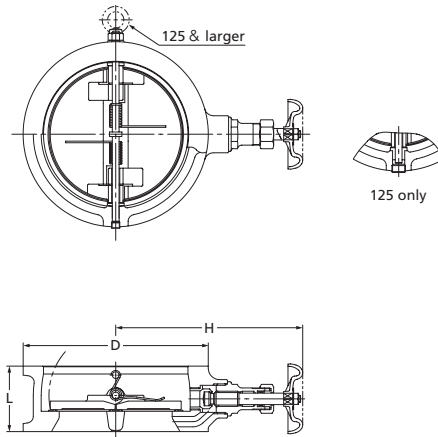
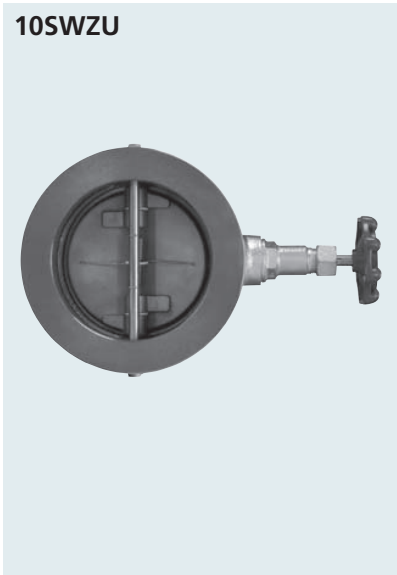

Face to face : KITZ Std.

80°C Static water 1.4MPa
80°C W.O.G. 1.0MPa

● 윤활 또는 유압 오일에 사용할 수 있습니다.

● Copper Cap을 사용하면 Ammonia 또는 Amine화합물질을 다루는데 해당 밸브를 사용할 수 없습니다.

Materials

Parts	JIS material
Body	FCD-S + NBR
Bonnet	FCD-S
Stem	SUS420J2
Disc	SCS13A
Plug *	S45CH
Spring	304SS
Gland	SUS420J2
Gland packing	Non-asbestos Packing
Handwheel	Ductile Iron

* 125 & smaller

Dimensions

Size	mm												
	50	65	80	100	125	150	200	250	300	350	400	450	
	2	2 1/2	3	4	5	6	8	10	12	14	16	18	
L	56	56	59	66	72	78	96	109	145	184	191	204	
H (open)	161	168	174	187	201	220	247	298	324	337	365	394	
D	101	121	131	156	187	217	267	330	375	420	483	538	

20K Wafer Check Valve

20SWZ

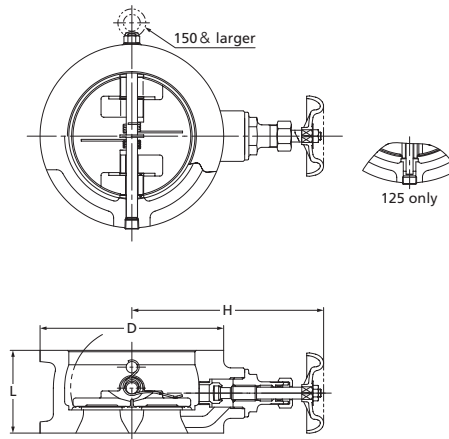
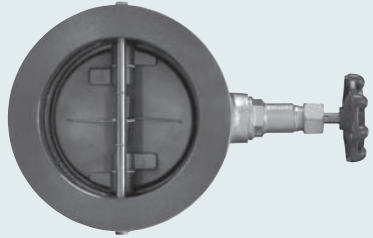

Face to face : KITS Std.

80°C Static water 2.8MPa
80°C W.O.G. 2.0MPa

- 윤활 또는 유압 오일에 사용할 수 있습니다.
- Copper Cap을 사용하면 Ammonia 또는 Amine 화학물질을 다루는데 해당 밸브를 사용할 수 없습니다.

Materials

Parts	JIS material
Body	FCD-S + NBR
Bonnet	CAC406 (40 ~ 125 : C3771)
Stem	C3531 (Tensile Strength and elongation shall be equal to or greater than those for C3771 in JIS H 3250)
Disc	CAC406
Plug *	S45CH
Spring	304SS
Gland	C3604
Gland packing	Non-asbestos Packing
Handwheel	Ductile Iron (40 : Aluminum Die-cast)

* 125 & smaller

Dimensions

Size	mm													
	mm	40	50	65	80	100	125	150	200	250	300	350	400	450
	inch	1½	2	2½	3	4	5	6	8	10	12	14	16	18
L		54	56	60	67	68	83	95	127	140	181	184	191	204
H (open)		128	133	150	156	169	183	216	243	290	315	330	355	388
D		86	101	121	137	162	200	235	280	353	403	447	507	572

20K Wafer Check Valve

20SWZU

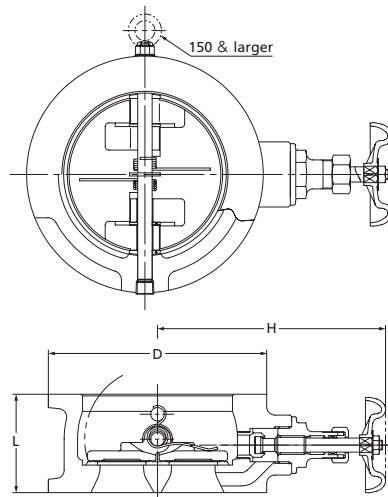
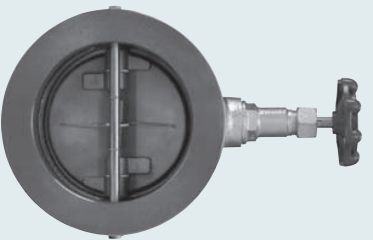

Face to face : KITS Std.

80°C Static water 2.8MPa
80°C W.O.G. 2.0MPa

- 윤활 또는 유압 오일에 사용할 수 있습니다.
- Copper Cap을 사용하면 Ammonia 또는 Amine 화학물질을 다루는데 해당 밸브를 사용할 수 없습니다.

Materials

Parts	JIS material
Body	FCD-S + NBR
Bonnet	FCD-S
Stem	SUS420J2
Disc	SCS13A
Plug *	S45CH
Spring	304SS
Gland	SUS420J2
Gland packing	Non-asbestos Packing
Handwheel	Ductile Iron

* 125 & smaller

Dimensions

Size	mm													
	mm	50	65	80	100	125	150	200	250	300	350	400	450	
	inch	2	2½	3	4	5	6	8	10	12	14	16	18	
L		56	60	67	68	83	95	127	140	181	184	191	204	
H (open)		146	168	174	187	201	219	247	297	324	337	365	394	
D		101	121	137	162	200	235	280	353	403	447	507	572	

Memo

A large grid of dotted lines for writing notes, covering most of the page.

Steel Pipe Flange Dimensions

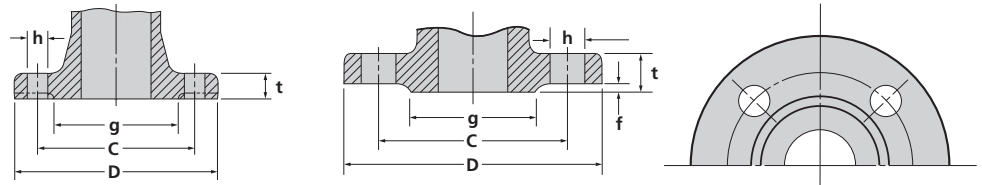

f : Height of raised face

JIS B 2239-2013

JIS 10K Steel Pipe Flange Dimensions

Nominal Size		Flange Diam. (D)	Dimension of Flange Part			Bolt Holes			Bolt Size
mm	inch		Thickness (t)	Raised Height (f)	Face Diam. (g)	Circle Diam. (C)	Number	Hole Diam. (h)	
10	3/8	90	12	1	46	65	4	15	M12
15	1/2	95	12	1	51	70	4	15	M12
20	3/4	100	14	1	56	75	4	15	M12
25	1	125	14	1	67	90	4	19	M16
32	1 1/4	135	16	2	76	100	4	19	M16
40	1 1/2	140	16	2	81	105	4	19	M16
50	2	155	16	2	96	120	4	19	M16
65	2 1/2	175	18	2	116	140	4	19	M16
80	3	185	18	2	126	150	8	19	M16
100	4	210	18	2	151	175	8	19	M16
125	5	250	20	2	182	210	8	23	M20
150	6	280	22	2	212	240	8	23	M20
200	8	330	22	2	262	290	12	23	M20
250	10	400	24	2	324	355	12	25	M22
300	12	445	24	3	368	400	16	25	M22
350	14	490	26	3	413	445	16	25	M22
400	16	560	28	3	475	510	16	27	M24

JIS 16K Steel Pipe Flange Dimensions

JIS B 2239-2013

Nominal Size		Flange Diam. (D)	Dimension of Flange Part			Bolt Holes			Bolt Size
mm	inch		Thickness (t)	Raised Height (f)	Face Diam. (g)	Circle Diam. (C)	Number	Hole Diam. (h)	
10	3/8	90	12	1	46	65	4	15	M12
15	1/2	95	12	1	51	70	4	15	M12
20	3/4	100	14	1	56	75	4	15	M12
25	1	125	14	1	67	90	4	19	M16
32	1 1/4	135	16	2	76	100	4	19	M16
40	1 1/2	140	16	2	81	105	4	19	M16
50	2	155	16	2	96	120	8	19	M16
65	2 1/2	175	18	2	116	140	8	19	M16
80	3	200	20	2	132	160	8	23	M20
100	4	225	22	2	160	185	8	23	M20
125	5	270	22	2	195	225	8	25	M22
150	6	305	24	2	230	260	12	25	M22
200	8	350	26	2	275	305	12	25	M22
250	10	430	28	2	345	380	12	27	M24
300	12	480	30	3	395	430	16	27	M24
350	14	540	34	3	440	480	16	33	M30
400	16	605	38	3	495	540	16	33	M30

JIS 20K Steel Pipe Flange Dimensions

JIS B 2239-2013

Nominal Size		Flange Diam. (D)	Dimension of Flange Part			Bolt Holes			Bolt Size
mm	inch		Thickness (t)	Raised Height (f)	Face Diam. (g)	Circle Diam. (C)	Number	Hole Diam. (h)	
10	3/8	90	14	1	46	65	4	15	M12
15	1/2	95	14	1	51	70	4	15	M12
20	3/4	100	16	1	56	75	4	15	M12
25	1	125	16	1	67	90	4	19	M16
32	1 1/4	135	18	2	76	100	4	19	M16
40	1 1/2	140	18	2	81	105	4	19	M16
50	2	155	18	2	96	120	8	19	M16
65	2 1/2	175	20	2	116	140	8	19	M16
80	3	200	22	2	132	160	8	23	M20
100	4	225	24	2	160	185	8	23	M20
125	5	270	26	2	195	225	8	25	M22
150	6	305	28	2	230	260	12	25	M22
200	8	350	30	2	275	305	12	25	M22
250	10	430	34	2	345	380	12	27	M24
300	12	480	36	3	395	430	16	27	M24
350	14	540	40	3	440	480	16	33	M30
400	16	605	46	3	495	540	16	33	M30

Steel Pipe Flange Dimensions

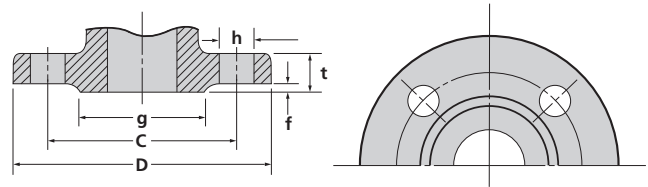

f : Height of raised face

ASME B 16.5-1996

Class 150 Steel Pipe Flange Dimensions

Nominal Size		Flange Diam. (D)	Dimension of Flange Part			Bolt Holes			Bolt Size
mm	inch		Thickness (t)	Raised Height (f)	Face Diam. (g)	Circle Diam. (C)	Number	Hole Diam. (h)	
15	1/2	89	11	1.6	35	60.5	4	16	1/2
20	3/4	98	12.7 (11.1)	1.6	43	70.0	4	16	1/2
25	1	108	14.3 (11.1)	1.6	51	79.5	4	16	1/2
32	1 1/4	117	15.9 (12.7)	1.6	64	89.0	4	16	1/2
40	1 1/2	127	17.5 (14.3)	1.6	73	98.5	4	16	1/2
50	2	152	19.1 (15.9)	1.6	92	120.5	4	19	5/8
65	2 1/2	178	22.3 (17.5)	1.6	105	139.5	4	19	5/8
80	3	190	23.9 (19.1)	1.6	127	152.5	4	19	5/8
100	4	229	23.9	1.6	157	190.5	8	19	5/8
125	5	254	23.9	1.6	186	216.0	8	22	3/4
150	6	279	25.4	1.6	216	241.5	8	22	3/4
200	8	343	28.6	1.6	270	298.5	8	22	3/4
250	10	406	30.2	1.6	324	362.0	12	25	7/8
300	12	483	31.8	1.6	381	432.0	12	25	7/8
350	14	533	35.0	1.6	413	476.5	12	29	1
400	16	597	36.6	1.6	470	539.5	16	29	1

*() 속 치수는 밸브 플랜지를 나타냅니다.

Class 300 Steel Pipe Flange Dimensions

ASME B 16.5-1996

Nominal Size		Flange Diam. (D)	Dimension of Flange Part			Bolt Holes			Bolt Size
mm	inch		Thickness (t)	Raised Height (f)	Face Diam. (g)	Circle Diam. (C)	Number	Hole Diam. (h)	
15	1/2	95	14.3	1.6	35	66.5	4	16	1/2
20	3/4	117	15.9	1.6	43	82.5	4	19	5/8
25	1	124	17.5	1.6	51	89.0	4	19	5/8
32	1 1/4	133	19.1	1.6	64	98.5	4	19	5/8
40	1 1/2	156	20.7	1.6	73	114.5	4	22	3/4
50	2	165	22.3	1.6	92	127.0	8	19	5/8
65	2 1/2	190	25.4	1.6	105	149.0	8	22	3/4
80	3	210	28.6	1.6	127	168.0	8	22	3/4
100	4	254	31.8	1.6	157	200.0	8	22	3/4
125	5	279	35.0	1.6	186	235.0	8	22	3/4
150	6	318	36.6	1.6	216	270.0	12	22	3/4
200	8	381	41.3	1.6	270	330.0	12	25	7/8
250	10	444	47.7	1.6	324	387.5	16	29	1
300	12	521	50.8	1.6	381	451.0	16	32	1 1/8
350	14	584	54.0	1.6	413	514.5	20	32	1 1/8
400	16	648	57.2	1.6	470	571.5	20	35	1 1/4

CAUTION

Pressure-temperature ratings and other performance data published in this catalog have been developed from our design calculation, in-house testing, field reports provided by our customers, and / or published official standards or specifications. They are good only to cover typical applications as a general guideline to users of KITZ products introduced in this catalog.

KITZ Ductile Iron Paintings are suitable for general service conditions. For Painting used in severe atmospheres or at elevated temperatures. Please contact us for recommendations based on your service environment.

For any specific application, users are kindly requested to contact KITZ Corporation for technical advice, or to carry out their own study and evaluation for proving the suitability of these products to such an application. Failure to follow this request could result in property damage and / or personal injury, for which we shall not be liable.

While this catalog has been compiled with the utmost care, we assume no responsibility for errors, impropriety, or inadequacy. Any information provided in this catalog is subject to from-time-to-time change without notice for error rectification, product discontinuation, design modification, new product introduction, or any other cause that KITZ Corporation considers necessary. This edition cancels all previous issues.

Read the instruction manual carefully before use.

NOTICE

If any products designated as strategic material in the Foreign Exchange and Foreign Trade Law, Cabinet Order Concerning Control of Export Trade, Cabinet order Concerning Control of Foreign Exchange, and other related laws and ordinances ("Foreign Exchange Laws") are exported to any foreign country or countries, an export license issued by the Japanese Government will be required under the Foreign Exchange Laws.

Further, there may be cases where an export license issued by the government of the United States or other country will be required under the applicable export-related laws and ordinances in such relevant countries.

The contract shall become effective subject to the fact that a relevant export license is obtained from the Japanese Government.

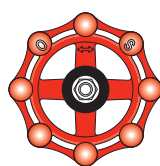

*A chrysanthemum-handle is a symbol of KITZ,
the brand of valve reliability*

ISO 9001 certified since 1989

KITZ
KITZ CORPORATION

1-10-1, Nakase, Mihama-ku, Chiba 261-8577, Japan
International Sales Dept.
Phone : 81-43-299-1730
Fax : 81-43-299-0121

— Distributed by —